



The best finishing starts here

Leading solutions for the self-adhesive label converting and finishing industry





WELCOME TO GM

The world of digital printing is changing.
GM gives you the automated digital finishing
solutions to lead the way.

Smarter solutions that help you adapt faster,
deliver sooner, print better and grow bigger.
So you stay competitive while the market
keeps moving.

Whether you do the printing or make the printers,
we know that finishing is just the start of a great
brand experience for your customers.

That's why we help you finish ahead of the rest.

Uffe Nielsen
CEO, GM



FOUR DECADES OF FINISHING ONE FOCUS: VALUE

For over 40 years, GM has engineered best-in-class solutions for the self-adhesive label converting, finishing and flexible packaging industry. Machines that are faster, smarter, tougher, easier – backed by peerless service and support.

Since we began, our company has pursued one single-minded mission: to deliver better value for our label printer and OEM customers than any other provider. We do this in five ways.

1. PUTTING YOUR REVENUE FIRST

From our initial contact, we focus on your commercial needs – making sure you're making the right investment, that your choice of equipment is fit for purpose, will deliver shorter lead times with higher quality, and can scale with your business.



2. FOCUSING ON THE BENEFITS

Features are great, benefits are better. We focus on innovative solutions that deliver measurably better results – so you don't just deliver a more efficient service to your customers, you deliver a more valuable brand experience.

3. HELPING YOU STAY AHEAD

The competition never stops, which is why we keep innovating. We offer more advanced technology so you stay in the lead – from fully automated converting lines to new printing processes, protected by built-in 24/7 support.

4. MAXIMIZING SPECS, MINIMIZING SPACE

Packing in more functionality can result in packing out a machine's size. Not with GM. Our "smart and compact" design philosophy means our equipment manages to provide even more functionality yet with an even smaller footprint.



5. PROTECTING UPTIME, ALL THE TIME

Time isn't just money, it can cost reputation too. That's why GM machines are designed to be dependable, and built to last. To keep business running smoothly at all times, we also provide preventative maintenance and 24/7 support with ultra-fast troubleshooting.

OUTSTANDING SERVICE

We put the same effort into building our partnership with you as we do into building our machines – helping maximize the benefits of your investment. Because, while new equipment can be pivotal for growing your brand, we know the real proof of value comes after installation.

LIFETIME SUPPORT

Throughout the life of your converting or finishing equipment, we make sure you're supported with all the training, service, maintenance, and spare parts you need.



Our dedicated GM Tech Support Team is always on call, comprising specialist engineers with decades of experience – from mechanics and electronics to software and connectivity.

Based at our company HQ in Birkerød, near Copenhagen, the team has direct access to our production and R&D departments, enabling them to quickly analyse issues and make accurate assessments.

In addition to a one-year limited warranty guarantee, all machines include a comprehensive reference library of technical documents, training videos and operating instructions. This allows your operators to solve many issues themselves.

ALL YOU NEED TO SUCCEED

As you will see in the following pages, GM produces and delivers a vast array of innovative and compact machines encompassing complete automated converting lines.

Hot foil stamping, screen printing, (laser) die cutting, slitter-rewinders, roll lifters, sheeters, core cutters... our latest developments are a new hot foil module and high-speed screen print add-ons to our flagship DC350Flex-series.

You name it, when it comes to converting and finishing we make it. And if we don't, GM will customise your dream machine for you.



INDEX

LABEL FINISHERS

DC350Flex* / DC550Flex*	10
DC350Flex / DC550Flex	12
Finishing designs	14
DC350Mini	16
DC350Nano	18

LASER FINISHER

LC350	22
-------	----

MODULE OPTIONS

SmartView	26
MultiLayer	26
AutoKnives	26
PlateLoader	27
Quick CrushKnives	27
AutoTurret	27
SemiTurret	27
FastStrip	28
ChillDrum	28
Buffers and synchronizers	28
DVM350	29

HOT FOIL / SCREEN PRINTERS

DC350Flex* Wine	32
HF350	34

SLITTER REWINDERS / INSPECTION

SR350/550	38
IR350	39
LR250*	40
LR250	41

LAMINATORS & COATERS

LA330	44
DS330	45
UC500	46
UC500*	47
IC30	48
EB30	49
XP500	50

AUXILIARY EQUIPMENT

CS350/550	52
CC160/200	53
QuickMount	54
RT Roll Lifter	55
GM Camera inspection systems	55
GR80K	56
GR100	56
LRW500	57
LUW500	57

CONFIGURATION EXAMPLES 58



Label finishers



DC350Flex⁺ /550Flex⁺

High-end modular finishing line

- PLUS-series is fully customizable
- Maximum modularity
- Fast speed die module – up to 130 m/min
- Automated production
- Integrated flat bed hotfoil and screen options
- Digital spot varnish option
- Jumbo roll unwinder and rewinder
- Online support and remote diagnostics



DC350/550Flex⁺ is a premium finishing line that provides the best in fast and automated finishing.

Featuring high-speed, semi-rotary varnishing and die-cutting as standard, this modular platform can be easily upgraded with value-added options like digital embellishment (DVM350), multilayer label, laser die cutter, hot foil, screen-printing modules, PlateLoader, and much more.

FLEXIBLE AND FUTURE PROOF

The DC350/550Flex⁺ platform is born to be modular, so if the market changes, new modules can be retrofitted quickly.

Even third-party technology, such as a digital spot varnish module, can be integrated for true hybrid production.

Bespoke client options are available on the PLUS-series.

DC350/550Flex⁺ is Industry 4.0 certified and fully compatible with all major digital presses.

This modular finishing platform sets completely new standards in the label industry, and will take your factory to the next level!



DIGITAL AND TOOL-FREE HIGH-END EMBELLISHMENT
Enables creation of astonishing varnish and foil effects, tactile finishes, dimensional effects and embossing embellishments.



QUICK JOB CHANGE
Production set-up and job changeover is faster, simpler, and more efficient on this automated platform.



PEEL AND REVEAL MULTI-LAYER
For printers who are looking to diversify their product offerings, the MultiLayer module is a perfect opportunity to move into special label applications.



ADAPTS TO ALL YOUR NEEDS
Regardless if your needs are to die-cut labels or to create high-quality embellishments with hot-foil, screen printing or digital varnish – this machine offers maximum machine modularity.

SPECIFICATIONS	METRIC	IMPERIAL
MODEL	DC350 ⁺ / DC550 ⁺	DC350 ⁺ / DC550 ⁺
Web width	50 - 350 mm / 50 - 550 mm	2 - 13.8" / 2 - 21.7"
Substrate thickness	50 - 200 µm / 50 - 200 µm	2 - 8 pt. / 2 - 8 pt.
DIE CUT STATION		
Max semi-rotary speed	80 m/min / 50 m/min	262 ft/min / 164 ft/min
Max full-rotary speed	130 m/min / 90 m/min	426 ft/min / 295 ft/min
Die plate size	50 - 558.8 mm / 50 - 558.8 mm	2 - 22" / 2 - 22"
UNWINDER		
Diameter max.	1000 mm / 700 mm	39.4" / 27.6"
Core diameter	76.2 mm / 76.2 mm	3" / 3"
REWINDER		
Diameter max. on dual shaft	700 mm / 500 mm	27.6" / 19.7"
Diameter max. on Turret	450 mm / 450 mm	17.5" / 17.5"
Standard core diameter	76.2 mm / 76.2 mm	3" / 3"
Waste matrix rewinder diameter	up to 800 mm on request	up to 31.5" on request
SEMI-ROTARY FLEXO STATION - FLOWER STYLE		
Print cylinder size	254 - 635 mm / 254 - 635 mm	10 - 25" / 10 - 25"
Spot varnish with digital sensor register control and slow run included.		
SLITTING STATION		
Knife type	Pneumatic Quick CrushKnives, Shear or AutoKnives.	
Minimum distance Quick Crush	27 mm / 27 mm	1.1" / 1.1"
Minimum distance shear	14 mm / 14 mm	0.55" / 0.55"
Minimum distance AutoKnives	15.5 mm / 15.5 mm	0.61" / 0.61"
DIMENSIONS		
W x D x H	Depends on configuration.	

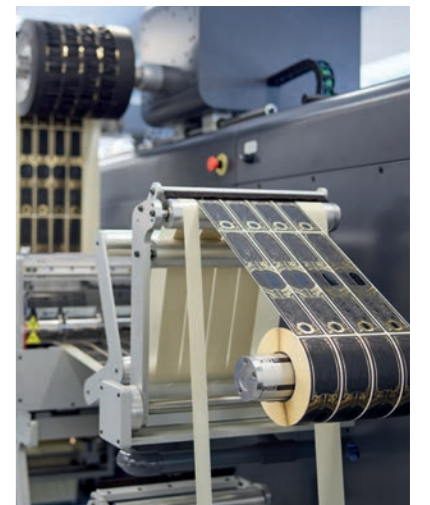

DC350Flex/ DC550Flex

Fast label finisher

- Short lead time on standard platform
- Maximum modularity
- Semi-rotary flexo with spot
- Automated slitting station
- FastStrip - high speed stripping
- Online support and remote diagnostics
- Industry 4.0 ready
- Available in 350 & 550 mm web width



DC350Flex is built for professional label printers with the need for a complete and versatile solution in high volume digital printing.

DC350Flex is an efficient and economical label finisher that is built with the same components as the DC350Flex*, and comes with handy options like format free semi-rotary spot varnish, semi-rotary die-cutting, slitting and dual rewind.

This modern platform ensures quick setup and flexibility along with an industry-leading user interface that gives the operator a graphical representation of the machine configuration and production flow.

Upgrade your production with value options like Turret rewinding, in-register lamination (MultiLayer), AutoKnives or Quick CrushKnives, FastStrip, Corona, web clean, back scoring & inline buffer.

Finally, DC350/550Flex is Industry 4.0 certified and prepared for in-line operation with all major digital presses.

This modular finishing platform will transform your production to the next level!



SUPERIOR END-RESULTS
A cost-efficient label finisher built for volume production of added-value labels, like multi-layer labels.



AUTOMATED OPERATION
Label production on this flexible and modern platform delivers quick setups and minimal waste. Improve productivity with less human intervention.



VALUE FOR CUSTOMERS
Create more value for your customers with foiling, spot varnish, and lamination.



MIS-SOFTWARE FOR EFFICIENCY
GM finishers are ready for integration with all digital label presses for full inline production. The possibility of integration with the MIS system software increases efficiency and automates the workflow at all levels in production.

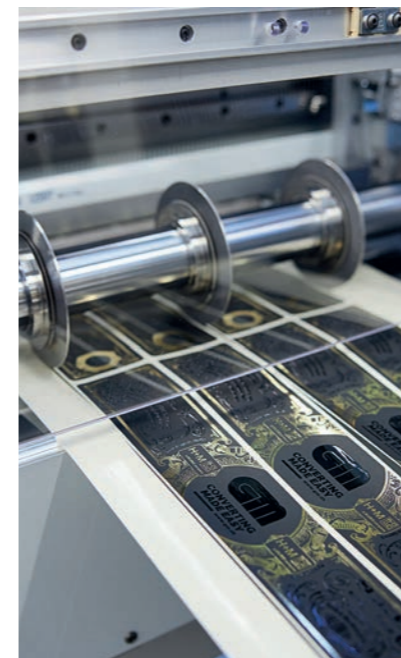

SPECIFICATIONS	METRIC	IMPERIAL
MODEL	DC350* / DC550*	DC350* / DC550*
Web width	50 - 350 mm / 50 - 550 mm	2 - 13.8" / 2 - 21.7"
Substrate thickness	50 - 200 µm / 50 - 200 µm	2 - 8 pt. / 2 - 8 pt.
DIE CUT STATION		
Max semi-rotary speed	80 m/min / 50 m/min	262 ft/min / 164 ft/min
Max full-rotary speed	130 m/min / 90 m/min	426 ft/min / 295 ft/min
Die plate size	50 - 558.8 mm / 50 - 558.8 mm	2 - 22" / 2 - 22"
UNWINDER		
Diameter max.	800 mm / 700 mm	31.5" / 27.6"
Core diameter	76.2 mm / 76.2 mm	3" / 3"
REWINDER		
Diameter max. on dual shaft	700 mm / 500 mm	27.5" / 19.7"
Diameter max. on Turret	450 mm / 450 mm	17.5" / 17.5"
Standard core diameter	76.2 mm / 76.2 mm	3" / 3"
Waste matrix rewinder diameter	up to 800 mm on request	up to 31.5" on request
SEMI-ROTARY FLEXTON STATION - FLOWER STYLE		
Print cylinder size	254 - 635 mm / 254 - 635 mm	10 - 25" / 10 - 25"
Spot varnish with digital sensor register control and slow run included.		
SLITTING STATION		
Knife type	Pneumatic Quick CrushKnives, Shear or AutoKnives.	
Minimum distance Quick Crush	27 mm / 27 mm	1.1" / 1.1"
Minimum distance shear	14 mm / 14 mm	0.55" / 0.55"
Minimum distance AutoKnives	15.5 mm / 15.5 mm	0.61" / 0.61"
DIMENSIONS		
W x D x H	4.0 x 1.6 x 1.7 m	13.1 x 5.3 x 5.7 ft



Finishing designs - the sky is the limit

Endless module options

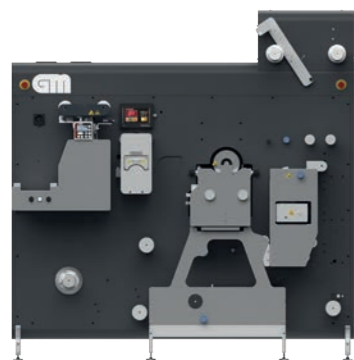

UNWINDER, SEMI-ROTARY FLEXO VARNISH, LAMINATION & COLD FOIL



DIGITAL VARNISH & COLD FOIL

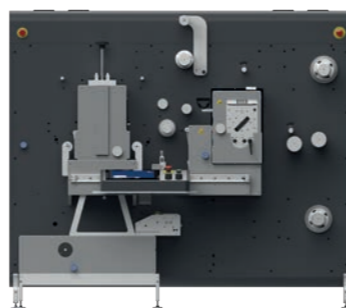

DIE CUTTER, AUTOKNIVES & DUAL REWINDER

Digital Embellishment solution

This solution makes room for unlimited creativity in digital embellishment by using the latest in inkjet technology. An excellent digital alternative to traditional screen printing as it operates on-demand and requires no tools or long and tedious preparation processes.

Digital Hybrid solution (Label Press)

A digital Label Finishing solution that combines the best features of digital and flexographic printing technology. An optimal and future proof solution for the food, cosmetics, beverages and pharma segments.

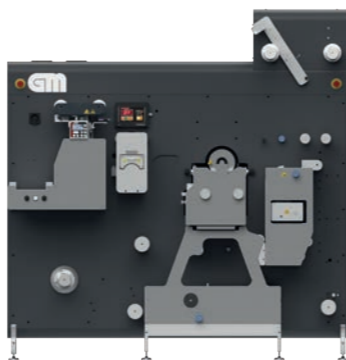

UNWINDER, SEMI-ROTARY FLEXO VARNISH, LAMINATION & COLD FOIL



DIGITAL LABEL PRESS

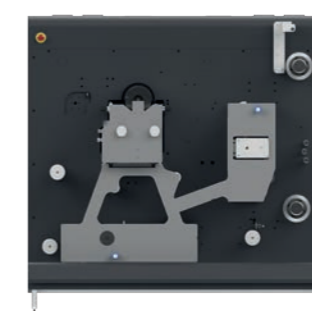

SEMI-ROTARY FLEXO VARNISH, LAMINATION & COLD FOIL

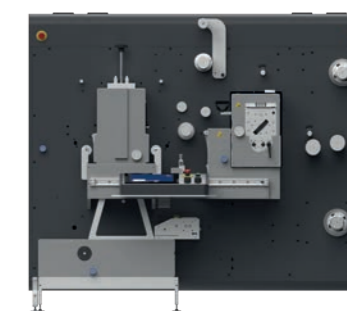

DIE CUTTER, AUTOKNIVES & DUAL REWINDER



UNWINDER



SEMI-ROTARY FLEXO VARNISH, LAMINATION & COLD FOIL

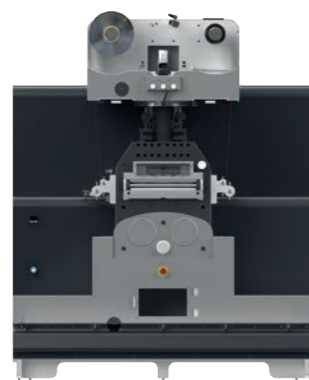

HOTFOIL

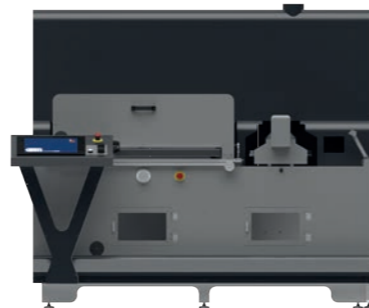

SCREEN

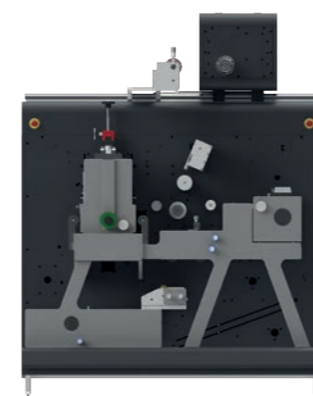

DIE CUTTER, FASTSTRIP & SLITTING



TURRET/AUTOTURRET REWINDER

Fully automated and fast solution

A 100% modular premium line with full flexibility in label finishing. With this solution you have all you need in label finishing. From traditional die cutting to high-value wine & spirit label embellishment.

This is certainly a game changer and will bring your label production to a new level!

DC350Mini

Compact label finisher

- Fastest ROI in the market
- High performance, precision cutting and ultrashort web path
- The fastest small footprint machine in the market
- "Swiss Army knife" converter
- Works inline with any digital press, GM hotfoil and screen embellishment units
- Train an operator in just one day
- Online support and remote diagnostics
- High performance - up to 80 m/min semi-rotary (optional)
- Industry 4.0 ready

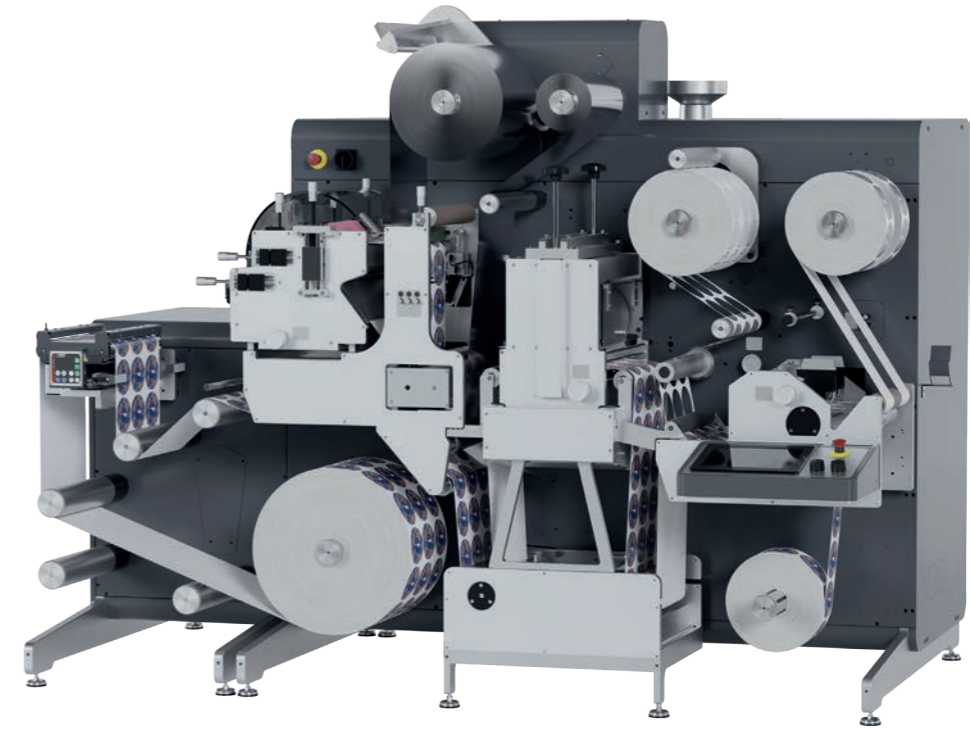

SMART FINISHING

DC350Mini provides full flexibility in finishing and die-cutting, you can even print an extra colour – the sky really is the limit with this powerful tool.



OPTIMISE INLINE AND OFFLINE

With an in-sync unit it is easy to switch between inline and offline mode. The buffer synchronizes the speed between digital press and finisher, and allows operator time to change the roll.

ALL-IN-ONE COMPACT SOLUTION

DC350Mini is developed in a small footprint to minimize waste and maximize productivity.

DC350Mini provides UV flexo varnish, lamination, cold-foil, die cutting and slit and dual rewind on one single compact platform.



UV FLEXP VARNISH STATION

Optional registration allows a higher level of embellishment with spot varnish and cold foil. Supports sleeves.

The drive train in the DC350Mini is completely servo driven offering low maintenance servo-driven tension control and good registration.

VERY USER-FRIENDLY

To optimise production the user-friendly touch screen is designed to give a graphical overview of e.g. machine configuration, spindle directions, web-path and active/non-active stage.

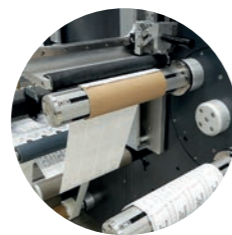

FAST JOBCHANGE

SemiTurret rewriter is designed for fast job change in label finishing. Saves time and eliminates 2-3% waste on short-run labels.

Accelerate your ambition with the DC350Mini backed up by multi-level support and great financing options from GM!



ULTRA-QUICK SET KNIVES

The Quick CrushKnives system, allows fast and precise setting of each crush knife – even while running.

SPECIFICATIONS	METRIC	IMPERIAL
Web width	50 - 350 mm	2 - 13.8"
Substrate thickness	50 - 200 µm	2 - 7.9 pt.
DIE CUT STATION		
Max semi-rotary speed	80 m/min	262 ft/min
Max full-rotary speed	130 m/min	426 ft/min
Die plate size	50 - 558.8 mm	2 - 22"
UNWINDER		
Diameter max.	700 mm (800 mm optional)	27.6" (31.5")
Core diameter	76.2 or 152.4 mm	3" or 6"
REWINDER		
Diameter max.	500 mm (800 mm optional)	19.7" (31.5")
Standard core diameter (min - max)	76.2 mm	3"
Waste matrix rewriter diameter	up to 800 mm on request	up to 31.5" on request
FLEXP STATION		
Print cylinder size	228 - 482.6 mm	9 - 19"
Spot varnish option with digital sensor register control and slow run.		
SLITTING STATION		
Knife type	Pneumatic crush, Quick CrushKnives, shear or razor	
Minimum distance crush / razor	13 mm	0.5"
Minimum distance Quick CrushKnives	27 mm	1.1"
Minimum distance shear	14 mm	0.55"
DIMENSIONS		
W x D x H	2.67 x 1.87 x 3.34 m	8.76 x 6.13 x 10.96 ft

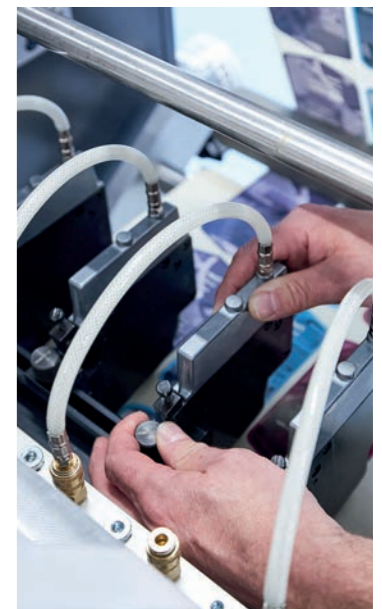

DC350Nano

Economic label finisher

- All you need to start label production
- Ideal for entry-level digital label printers
- High value for money
- Works inline with any digital label press
- Online support and remote diagnostics
- Lamination included
- Industry 4.0 ready
- Small foot print - just 1.6 meters (5.2 feet)

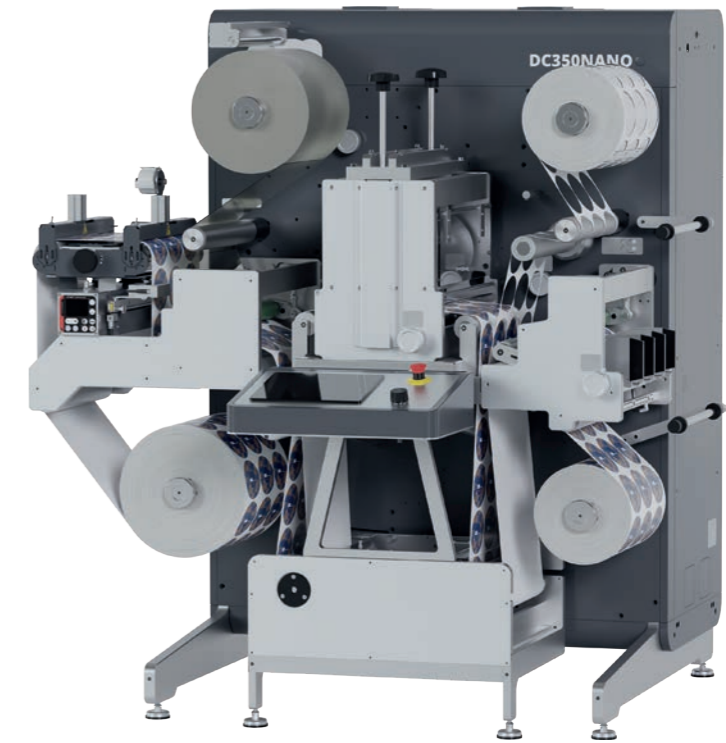

ALL-IN-ONE SOLUTION WITH MANY OPTIONS

The DC350Nano has all you need to start producing labels.

This ultra compact, cost-effective unit is built for self-adhesive lamination, semi-rotary die-cutting and length slitting of label web widths up to 350mm.

The DC350Nano is the most compact unit in GM's series of label finishing machines and is an ideal finisher for a small digital press or as a backup to an existing finishing line.

DC350Nano is built on the same rock-solid die cut unit as our DC350Flex+ high-end modular converting line.

To upscale your production even further you can add valuable options to the DC350Nano like VPN GATEWAY, inline sync unit, advanced stripping roller system, and extra Mark Reader.

DC350Nano is all you need to start producing labels!



INLINE OR OFFLINE

DC350Nano can be set up as an inline extension to a digital label press, allowing the web to continue directly into the converter from the digital press or as a standard offline unit.

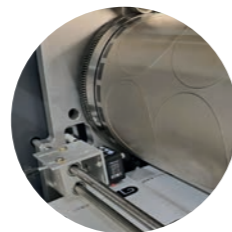

SOLID AS A ROCK

DC350Nano is built with the same smoothness in design and craftsmanship as our high-end DC350Flex series.



MINIMUM WASTE

The compact design in the DC-350Nano ensures a very quick print-to-cut registration, hence minimum waste.



WORKS INLINE WITH HOTFOIL

DC350Nano produces highly embellished labels with the use of hot stamping and embossing.

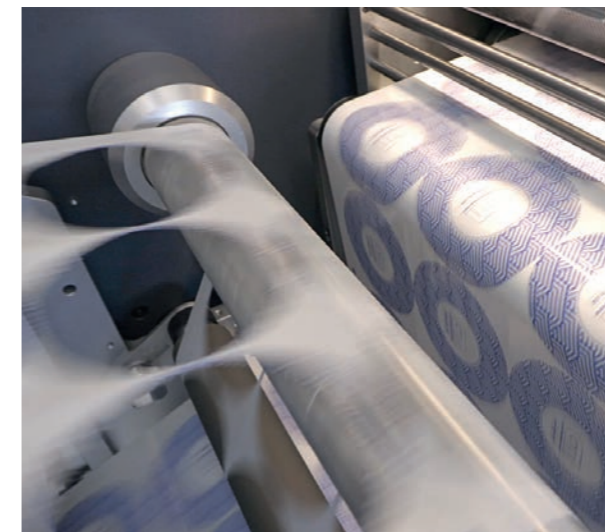

SPECIFICATIONS	METRIC	IMPERIAL
Web width	50 - 350 mm	2 - 13.8"
Substrate thickness	50 - 200 µm	2 - 8 pt.
DIE CUT STATION		
Semi-rotary speed	45 m/min	148 ft/min
Full-rotary speed	130 m/min	426 ft/min
Die plate size	50 - 558.8 mm	2 - 22"
UNWINDER		
Diameter max.	500 mm	19.7"
Core diameter	76.2 or 152.4 mm	3 or 6"
REWINDER - STANDARD SINGLE SHAFT		
Diameter max.	400 mm	15.7"
Standard core diameter	76.2 mm	3"
SLITTING STATION		
Knife type	Pneumatic crush, Quick CrushKnives	
Minimum distance crush	12.7 mm	0.5"
Minimum distance Quick CrushKnives	27 mm	1.1"
DIMENSIONS		
W x D x H	1.6 x 1.6 x 1.7 m	5.2 x 5.2 x 5.6 ft



Laser finisher



LC350

Laser finisher

- Excellent choice for any digital label press
- Fully digital mirror system for superior laser cut quality
- High-performance LUXINAR sealed lasers
- Precise register and cut depth control
- Zero changeover time - job change on the fly
- No die cut plate cost
- Online support and remote diagnostics
- Industry 4.0 ready

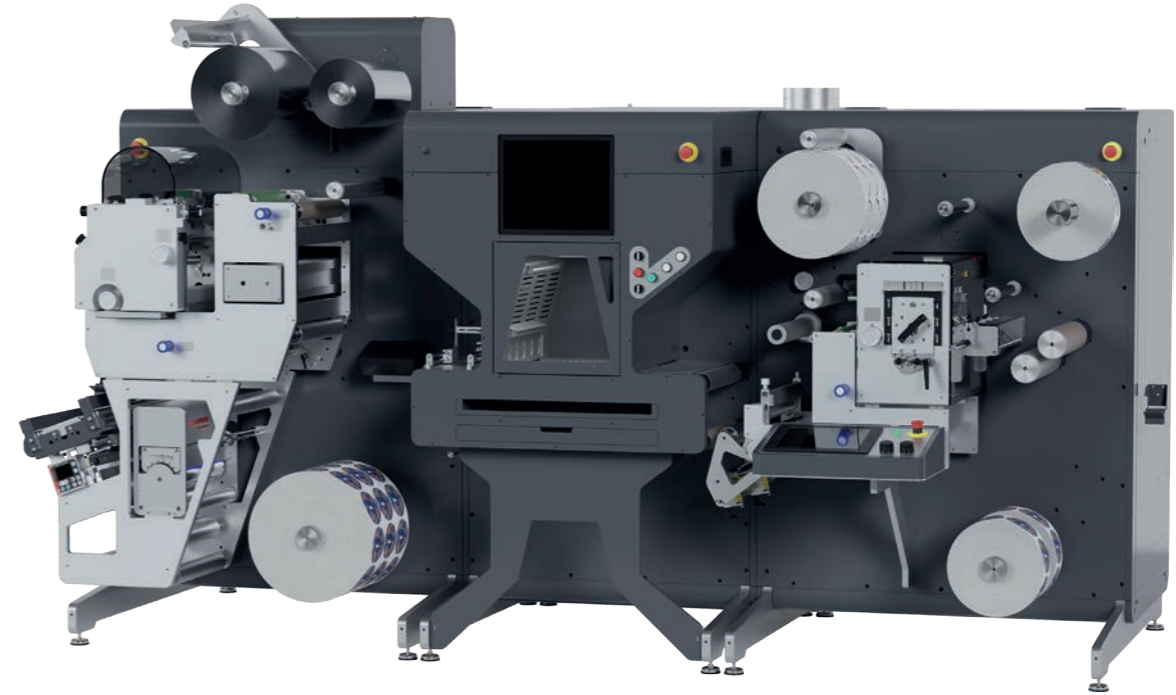

The LC350 is a compact, economical and fully digital laser finisher and an excellent choice for a digital label press.

QUICK DELIVERY

With near to zero setup time for existing and new jobs, this laser finisher counters the challenges of smaller runs and challenging lead times. An investment in the LC350 will give you continuous production, increase efficiency and productivity and enable day-to-day delivery of labels.

COST SAVING

Save the cost of buying conventional die cut plates, and spare the time setting up new jobs. This cost-efficient laser die cut solution will increase the flexibility in your production facility.

LC350 supports multiple laser processes and the laser beam will kiss-cut, slit, perforate and ablate most materials used in the label industry.

The standard configuration of LC350 has laser die cutting, varnish, slitting and dual rewind, and works based on a fully digital position system. This solution offers excellent register (X & Y) and cut-depth control, which gives you greater flexibility in the design of labels and an increase in precision and quality of label edges.

The laser module of LC350 is designed to fit into any GM converting line, such as DC350Flex+, with minor electrical and mechanical modifications.

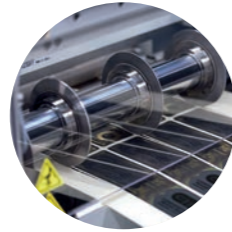

FLEXIBILITY AND AUTOMATION

The advantages of laser die cutting are flexibility, precision, repeatability, speed, cost-effectiveness, great quality, versatility and automation possibilities. AutoKnives make production 100% tool-free.

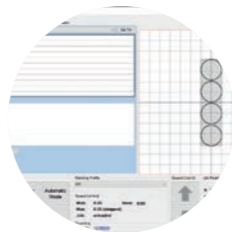

TOOL FREE / ZERO SETUP TIME

Eliminates downtime for setups of mechanical dies, while increasing your design possibilities to more complex and intricate arrangements of high accuracy.



DAY-TO-DAY DELIVERY

You can quickly upload a job to the LC350 and begin cutting. Jobs can continuously be readjusted for quick runs and also be saved and easily recalled.



JOB CHANGE WHILE RUNNING

You don't need to stop the machine to change jobs. The software will do it for you automatically. Save time, reduce waste and eliminate vast tooling expenses.

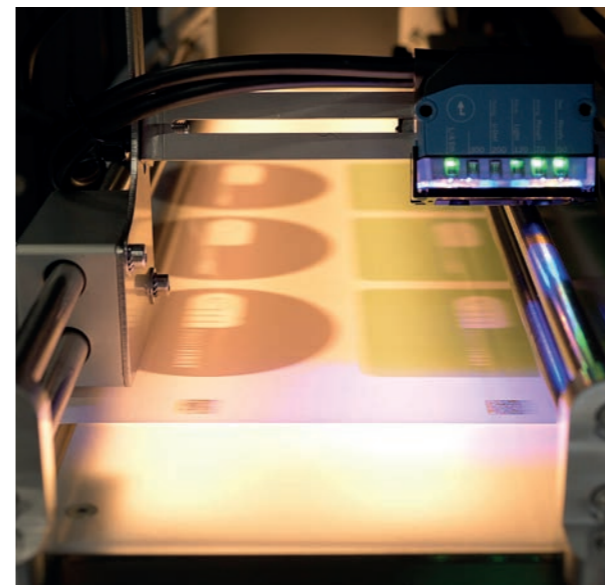

SPECIFICATIONS	METRIC	IMPERIAL
Web width	50 - 350 mm	2 - 13.8"
Substrate thickness	20 - 200 µm	0.8 - 8 pt.
Max machine speed	72 m/min	236 ft/min
LASER DIE		
Power	175 W, 250 W or 350 W	
Laser type	Sealed, single head pulsed CO ₂	
UNWINDER		
Diameter max.	700 mm	27.6"
Core diameter	76.2 - 152 mm	3" - 6"
REWINDER		
Diameter max. lower rewind	600 mm	23.6"
Diameter max. upper rewind	500 mm	19.7"
Core diameter	25.4 - 152.4 mm	1 - 6"
FLEXO STATION		
Varnishing roller	229 - 635 mm	9 - 25"
Spot varnish option with registration and slow run		
SLITTING STATION		
Knife type	Pneumatic crush, shear, razor or AutoKnives	
Minimum distance crush	12.7 mm	0.5"
Minimum distance shear	14 mm	0.55"
Minimum distance AutoKnives	15.5 mm	0.61"
DIMENSIONS		
W x D x H	3.5 x 2.9 x 2.2 m	11.6 x 9.4 x 7.1 ft



Module options

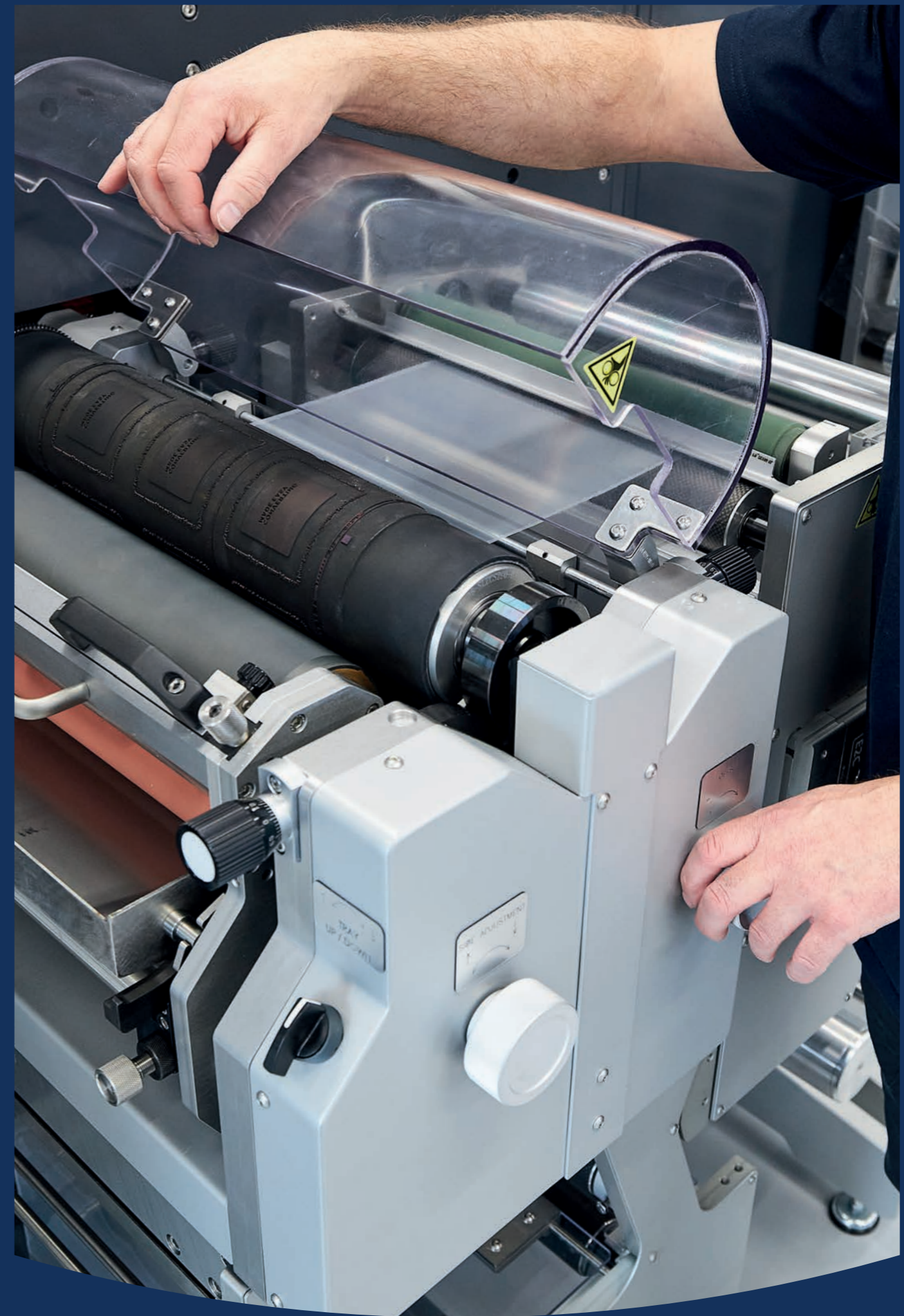

Module options



SmartView

We have built the GM SmartView dashboards so that the entire production flow is visualised in quite a simple way and in real-time data. This full factory overview makes it easy to see if the daily production targets are met or a machine is down, so productivity can be optimised.

The system is designed on an open software platform that is compatible with most of the MIS systems used in our industry, including MIS-software or solutions such as Microsoft Power BI (Business Intelligence). An ideal automated Industry 4.0 system.

The graphical touch screen shows the machine configuration, spindle directions and web-up.

THE LIVESTREAM SHOWS:

- Operator Name
- Job ID
- Current machine status (Run, Idle, Error)
- Current web speed
- Current distance run

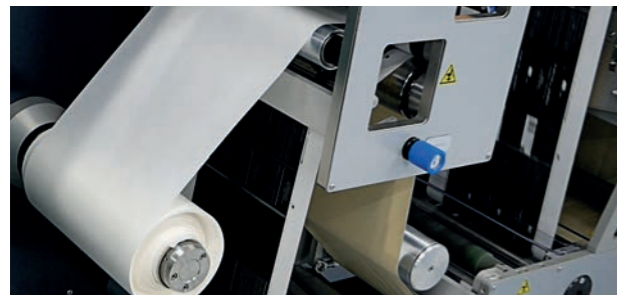

MultiLayer

Multi-layer labels are often used for pharmaceutical and medical label applications – especially when government regulations require product information to remain intact with the product. With a multi-layer label, you can also add recipes on food labels, promote sweepstakes / giveaways, detailed instructions, give multilingual information, launch a new product, attract buyers with coupons and display legal text.

SPECIFICATIONS	METRIC	IMPERIAL
Web width	350 and 550 mm	13.8 and 21.6"
Speed	up to the max machine speed	
Substrate thickness	30 - 60 µm	1.2 - 2.4 pt.
Verified Substrates	PP on Silicone Liner	
Repeat length	50 - 999.99 mm	2 - 393.70"
Made for	DC350/550Flex, DC350/550Flex*	

AutoKnives

The AutoKnives automatic knife box can set your slitting knives in three different ways: Fill in the table on the touchscreen with the size of your labels, scan the generated QR-code or simply reload an existing job from the control system. Then simply press "Place" on the touchscreen and the automatic knife box will set the knives according to your request in a matter of seconds. Set 16 knives in less than two minutes.

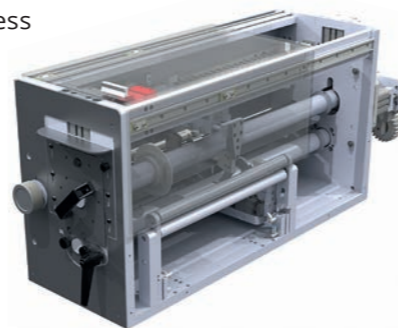

SPECIFICATIONS	METRIC	IMPERIAL
Web width	350 and 550 mm	13.8 and 21.6"
Substrate thickness	50 - 200 µm	2 - 8 pt.
Knife type	Rotary shear / optional razor blades	
Minimum distance between the knives	15.5 mm	0.61"
Minimum side trim	1 mm	0.04"
Number of knives	3 (default) / 16 max.	
Setup	QR-code, Key in, Manual	
Setup time	6 seconds / knife	
Made for	DC350/550Flex, DC350/550Flex*, SR350/550, LC350	

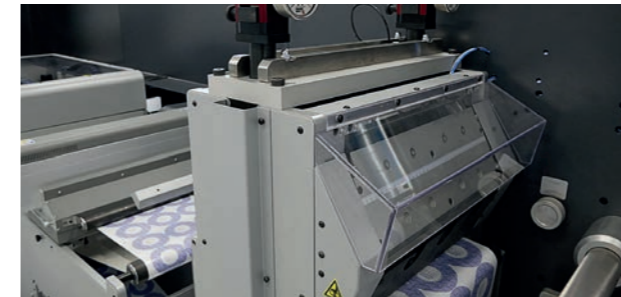

PlateLoader

An automatic flexible die cut plate changing system to reduce changeover times and to ensure an accurate die mounting in seconds – every time.

SPECIFICATIONS	METRIC	IMPERIAL
Die plate size	50 - 55.8 mm	2 - 22"
Web width	50 - 350 mm	2 - 13.8"
Changing time	10s	
Made for	DC350Flex*	



Quick CrushKnives

An ultra-quick set knives system for fast and precise setting of each crush knife – also while running.

SPECIFICATIONS	METRIC	IMPERIAL
Web width	330, 350, 550 mm	13.0, 13.8, 21.6"
Minimum distance	27 mm	1.1"
Knife type	Pneumatic Quick CrushKnives	
Made for	DC350Nano, DC330Mini, DC350/550Flex, DC350/550Flex*, SR350/550, LC350	

AutoTurret

Fully servo controlled automatic turret rewriter that provides efficient production without stopping when changing rolls.

This unique solution allows smooth varnishing of labels with no traces of the wet roller onto the web.

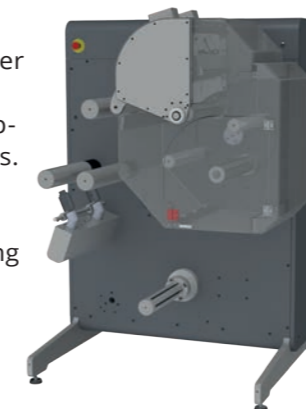

SPECIFICATIONS	METRIC	IMPERIAL
Web width	350 mm	13.8"
Rewind	2 position turret	
Diameter max on Turret	450 mm	17.5"
Diameter max on bottom shaft	700 mm	27.5"
Standard core diameter	76,2 mm	3"
Made for	DC350Flex*	

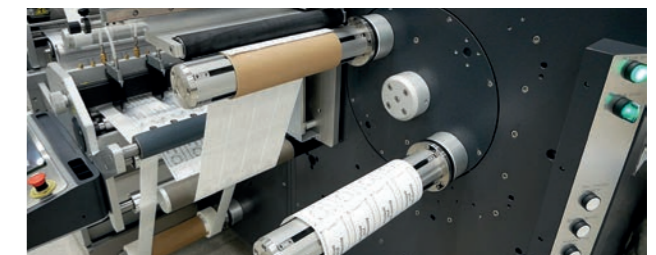

SemiTurret

GM SemiTurret is specifically designed for fast job change in label finishing and stops EXACTLY between the labels. This can save you not only time but also eliminate 2-3% waste on your short-run labels.

SPECIFICATIONS	METRIC	IMPERIAL
Web width	350 mm	13.8"
Rewind	2 position turret	
Diameter max on Turret	400 mm	15.7"
Diameter max on bottom shaft	500 mm	19.7"
Standard core diameter	76,2 mm	3"
Made for	DC330Mini, DC350 Mini, DC350Flex, DC350Flex*, SR350	



FastStrip

A remarkable waste matrix stripping and rewinding system with servo controlled tension. The waste matrix is peeled off around an idle rubber roller and immediately transferred to the rewinder (contact stripping). It ensures trouble-free operation even while converting delicate substrates and complex label shapes at high speed.

SPECIFICATIONS	METRIC	IMPERIAL
Web width	350 and 550 mm	13.8 and 21.6"
Speed	up to the max machine speed	
Made for	DC350/550Flex, DC350/550Flex*	

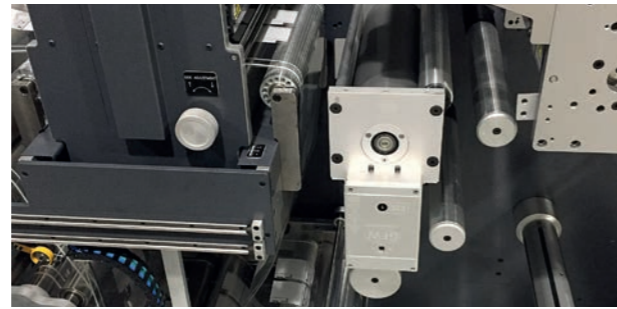

ChillDrum

The ChillDrum eliminates curling and melting issues while UV-curing of thin foil substrates. Installing the ChillDrum maximises the variety of substrates applicable. Ideal for filmic, thin foils, flexibles and shrink sleeves.

ChillDrum is retro-fittable!

SPECIFICATIONS	METRIC	IMPERIAL
Web width	330, 350 and 550 mm	13.0, 13.8 and 21.6"
Made for	DC330Mini, DC350Mini, DC350/550Flex, DC350/550Flex*	

Buffers and Synchronisers

The best of both worlds!

- Easy switch between inline and offline mode
- Synchronize the speed between digital press and finisher
- Allow operator time to change the roll
- Store up to 52 meters and allows up to 4 minutes of continuous production

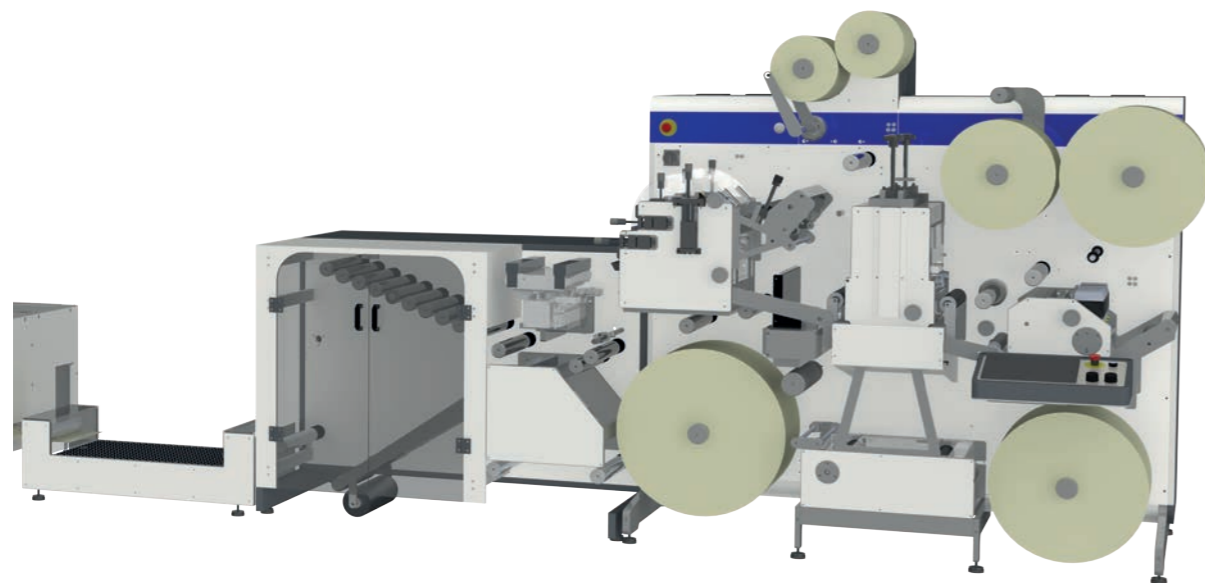

DVM350

Digital Varnish Module

- Tool-free operation and immediate job change
- Digital spot coating
- Digital embossing with high build varnish
- Tactile decoration increasing the aesthetic impression
- Metallic and hologram effects with foils
- Braille printing
- Warning triangles
- Personalized graphics and text



The DVM350 Digital Varnish Module uses the latest inkjet technology from XAAR - to deliver varnish height.

The module offers exciting exceptional printing capabilities and can carry out any combination of decorative processes in one pass, such as digital foiling with a 3D effect, spot coating, tactile screen and braille printing.

DVM350 is an excellent and cost efficient digital alternative to traditional screen printing as it operates on-demand and does not require long and tedious preparation processes.

This is a complete ready-to-use system with a full workflow solution that typically twice as fast as conventional screen. The system delivers flawless high-build solid areas and protective coatings.

DVM350 is based on special UV ink heads, that are compatible with all materials, incl. natural ones - without special pre-treatment for printing.

Make your labels truly unique and stand out from all other products on the shelves!

SPECIFICATIONS	METRIC	IMPERIAL
Web width	200 - 350 mm	8 - 13.8"
Substrate thickness	100 - 250 µm	4 - 10 pt.
Speed max	50 m/min	164 ft/min
Build heights	up to 280 µm (*with double print bar)	
Grey levels	up to 8	
Print resolution	720 dpi	
Drop sizes	6 - 40 pl	
Ink type	UV varnish	
Made for	DC350Flex, DC350Flex*, LC350	



ALL IN ONE PROCESS
Combing decorative processes in one pass, such as digital foiling with a 3D effect, spot coating, tactile screen and braille printing.



WORKS WITH ALL MATERIALS
No special pre-treatment - which makes DVM 350 an excellent digital alternative to traditional screen printing.



INDUSTRIAL SOLUTION
Based on the well-known Xaar-inkjet technology.



VERY FAST
DVM350 is twice as fast as conventional screen printing and operates on-demand. No long and tedious preparation processes.



Hot foil / Screen printers



DC350Flex⁺ Wine

Dedicated wine label finishing line

- Maximum modularity
- Fast speed die module – up to 130 m/min
- Automated production
- Digital spot varnish option
- Adapt quickly to industry changes
- 50 tons hot foil unit with build in foil saver & turning foil tower
- Online support and remote diagnostics



ENTER LUXURY MARKETS WITH HIGH-END EMBELLISHMENT

You have only seconds to capture a consumer's attention to get them to notice your bottle, pick it up, and ultimately purchase it. The DC350Flex⁺ Wine will make your labels stand out in a sea of wine options. DC350Flex⁺ Wine is a premium finishing line that provides the best in fast and highly automated wine finishing.



FAST - WITH TENSION CONTROL
Fast and heavy-weight hot foil unit applies up to 50-ton. Servomotors on unwinder and rewinder for excellent web tension control.

Featuring high-speed, hot-foil, screen varnish, semi-rotary flexo varnishing, and die-cutting as standard, this modular platform can be easily upgraded with value-added options like digital embellishment DVM350, multilayer label, laser die cutter, and much more.



HOT FOIL & EMBOSING
DC350Flex⁺ Wine delivers both hot foil, cold embossing, and advanced options such as foil saver and hologram-register - to serve all your needs. DC350Flex⁺ Wine offers Electronic temperature control and BST web-guide come as standard.

FLEXIBLE AND FUTURE PROOF

The DC350Flex⁺ Wine platform is born to be modular, so if the market changes, new modules can be retrofitted quickly. Even third-party technology, such as a digital spot varnish module, can be integrated for true hybrid production. Bespoke client options are available on the PLUS-series.



SCREEN PRINTING
A sophisticated high precision movable UV lamp cures exactly the thickness of varnish that is needed.

Finally, DC350Flex⁺ Wine is Industry 4.0 certified and prepared for in-line operation with all major digital presses.



ALL IN ONE PROCESS
The machine configuration also offers die cutting and slitting of the web using AutoKnives in one pass. This gives any label converter a new, more profitable way to enter luxury markets, such as high-end wine, spirits, and cosmetics.

This wine label finishing platform will take your label production to the next level!



SPECIFICATIONS	METRIC	IMPERIAL
Web width	50 - 350 mm	2 - 13.8"
Substrate thickness	50 - 200µm	2 - 8 pt.
HOTSTAMP		
Print area (along x across machine)	305 - 330 mm	12.0 - 13.0"
Max speed	70 m/min	230 ft/min
SCREEN		
Print area	350 x 350 mm	13.8 x 13.8"
Max speed	20 m/min	66 ft/min
DIE CUT STATION		
Semi-rotary speed	80 m/min	262 ft/min
Full-rotary speed	130 m/min	426 ft/min
Die plate size	50 - 558.8 mm	2 - 22"
UNWINDER		
Diameter max	800 mm	31.5"
Core diameter	76.2 mm	3"
REWINDER		
Diameter max on dual shaft	700 mm	27.6"
Core diameter	76.2 mm	3"
FLEXO STATION		
Print cylinder size	229 x 635 mm	9 x 25"
Spot varnish option with registration and slow run		
SLITTING STATION		
Knife type	Pneumatic Quick CrushKnives, AutoKnives	
Minimum distance Quick CrushKnives	27 mm	1.1"
Minimum distance AutoKnives	15.5 mm	0.6"
DIMENSIONS		
WxDxH	7.7 x 1.6 x 1.7 m	25.3 x 5.2 x 5.7 ft

HF350

Compact standalone Hot Foil

- Take your labels to next level with HF350
- Speed up to 90 m/min / 295 ft/min
- Servo-register system for printed marks or optional label gap sensor
- BST ultrasonic web guide
- Easy loading of plate and counter plate in the hot state
- Graphical touch screen with label counter, meter counter, alarms, and more
- Easy web access and maintenance
- Combine HF350 with DC350Mini and DC350Nano for an economical wine label finishing line
- Runs offline or inline with other GM converting machines

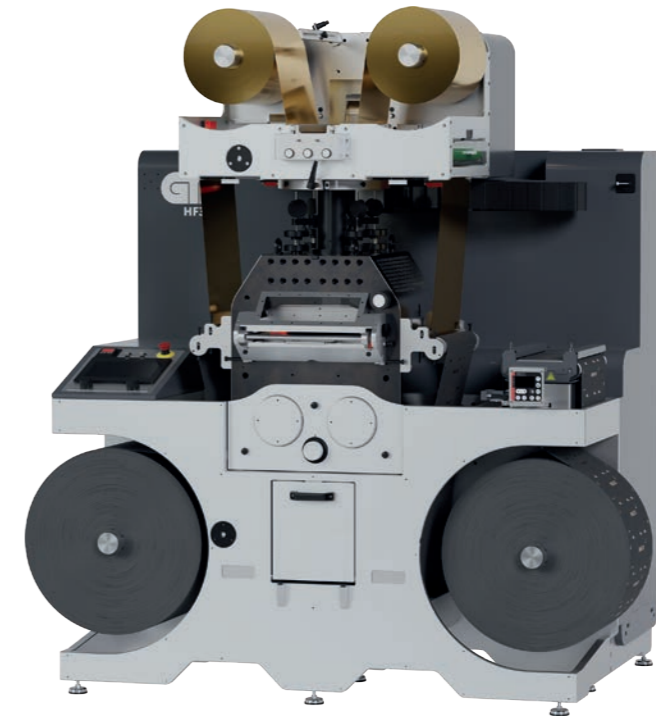

IMPRESS YOUR CUSTOMERS

The best way to impress consumers is the right combination of quality and beauty, and this is where the HF350 flatbed hot stamp unit will help you out.

The HF350 is an innovative unit that will give your labels an impressive and a unique look & feel.

The HF350 is very versatile — it delivers both hot foil and cold embossing to serve all your label printing needs.

BEST IN CLASS EMBELLISHMENT

HF350 delivers endless hot stamping possibilities e.g. with gold, silver or holographic effects and this combined with embossing will give great embellishment results to the labels.

In relation to quality in hot stamping, the HF350 flatbed technology is the best choice in the market, and in relation to beauty, the HF330 can add very thin lines and detailed elements of gold, silver or even holograms to your labels.

The HF350 offers advanced options such as foil saver and hologram-register. Electronic temperature control and BST web-guide come as standard, and operates inline with all finishing machines from GM.

This 50-ton precision hot stamper offers a world of finishing effects in one small device!



QUALITY AND RELIABILITY

Fast and heavy-weight hot foil unit applying up to 50-ton for perfect foil and embossing effects.

AMAZING EFFECTS WITH MULTIPLE FOIL STREAMS

Gold & Silver are classics, but special effects like clear foils for gloss imitations and high gloss signature black are possible as well.

FAST AND EASY JOB CHANGE

QuickMount enables very fast mount of male/female embossing plates. This mounting tool can save the operator many hours in job-change-hours every week.

ENTER THE NEW MARKETS

Add value to the labels and enter new luxury markets such as food, beverage and cosmetic products.

SPECIFICATIONS	METRIC	IMPERIAL
Web width	100 - 350 mm	2.5 - 13.8"
Substrate thickness	50 - 200 µm	2.0 - 7.9 pt.
HOT FOIL & EMBOSsing		
Speed	Up to 90 m/min	Up to 295 ft/min
Stamp plate size	330 x 330 mm	13 x 13"
Total thickness of the plate and counter plate	5 - 15 mm	0.2 - 0.6"
UNWINDER		
Diameter max.	600 mm	23.6"
Core diameter	76.2 or 152.4 mm	3 or 6"
REWINDER		
Diameter max.	600 mm	23.6"
Core diameter	76.2 to 152.4 mm	3 to 6"
DIMENSIONS		
W x D x H	1.75 x 1.25 x 2.15 m	5.74 x 4.1 x 7.05 ft



Mix colours and effects. Create amazing effect using multiple foil streams with different colours or effects. Gold & Silver are classics, but special effects like clear foils for gloss imitations and high gloss signature black is popular as well.



Foil and emboss: Emboss and foil in one tool. The precision of the GM flatbed system supports combo tools that foil and emboss in one go. This ensures perfect registration between the foiling and embossed features on the label.



Slitter Rewinders / Inspection



SR350/550

Slitter inspection rewinder

- High speed slitting up to 300m/min
- The shortest start/stop distance on the market
- 100% inspection
- Seated operator work position possible
- Semi-Automatic Turret



The SR350 is a highly reliable, high-speed slitter inspection rewind machine. The SR350 features the newest in servo motion technology and a unique option for AutoKnives.

Designed for a wide range of labels on paper and plastic liners, including the UPM PP30 and AD PET 23µm liners, booklet, tube laminate, Alufoil, Tyvek, cardboard, multilaminar.

OPEN CONCEPT, EASY UPGRADE AND QUICK SET-UP

Fully modular open concept allows to add the options such as 100% inspection camera, scanner QR-code reader, ink-jet systems, AutoKnives, waste vacuum ejector and turret rewinder.

Quick set-up routines with the build in job-recall system ensure all systems are ready to run simultaneously, making it faster to change jobs.



100% INSPECTION
Advanced label inspection system option. The machine stops within 10 cm if any errors are detected.



EASY WORKFLOW
Can easily combine SR350 with LC350 by using barcodes. Auto-Knives are also set automatically utilizing information from barcodes.

SPECIFICATIONS	METRIC	IMPERIAL
Web width	50 - 350 mm	2 - 13.8"
Substrate thickness	50 - 200 µm	2 - 7.9 pt.
Max speed	300 m/min	984 ft/min
Max speed with Camera Inspection	300 m/min	984 ft/min
UNWINDER		
Diameter max.	700 mm	27.6"
Core diameter	76.2 mm	3"
REWINDER - SINGLE, DUAL OR TURRET OPTION		
Diameter max.	500 mm	19.7"
Diameter max on Turret	400 mm	15.7"
Core diameter	25 - 152 mm	1 - 6"
SLITTING STATION		
Knife type	Pneumatic crush, shear, razor or AutoKnives	
Minimum distance crush / razor	12.7 mm	0.5"
Minimum distance shear	14 mm	0.55 mm
Minimum distance AutoKnives	15.5 mm	0.61"
Camera Inspection System	BST Tubescan, Nikka M+	
Webguide	BST Ultrasonic	
DIMENSIONS		
W x D x H	2.0 x 1.6 x 2.0 m	6.5 x 5.2 x 6.6 ft.
Dimensions with turret (WxDxH)	3.0 x 1.6 x 2.0 m	9.8 x 5.2 x 6.6 ft.

IR350

Pharma inspection rewinder

- Turn key pharma full inspection solution
- Bi-directional drive for inspection, rewind and re-inspection
- High quality inkjet coding and numbering
- Multilayer and warning label insertion

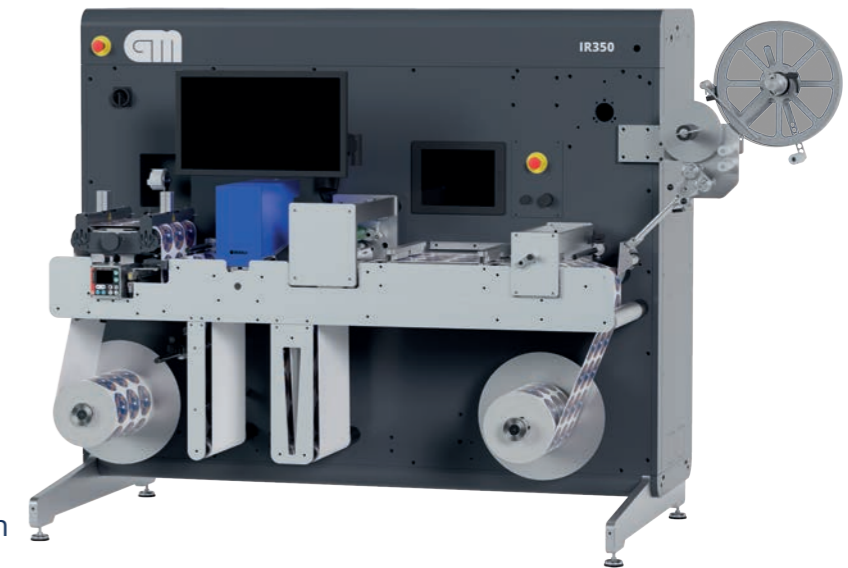

The IR350 is an inspection rewinder built on the most modern electronic platform. Converting webs in widths up to 350mm on rolls of max 400mm in diameter, the IR350 offers converting speeds of up to 200m/min.

IR350 is fully compliant with all requirements for pharmaceutical and safety controls characterized by high standards and the highest quality. It can be used for multiple operations depending on the configuration, including inspection, back-numbering, counting, slitting and multi-layer (peel & reveal) labels.

Thanks to the short inspection table the machine has a small footprint. It stops precisely for label inspection after detecting any errors.

100% INSPECTION

The system is bi-directional, which allows the users to back-up and re-check a defective label to make sure the job is 100% perfect.

The inspection camera system stops the machine when a fault is detected and moves the faulty label back to the repair table. The system can be fitted with cameras from Nikka, BST Tubescan, AVT or other suppliers according to client requirements.

SPECIFICATIONS	METRIC	IMPERIAL
Web width	350	13.8"
Substrate thickness	50 - 200 µm	2 - 7.9 pt.
Max speed	200 m/min	656 ft/min
Max unwind diameter	400 mm	15.7"
Max rewind diameter	400 mm	15.7"
Pneumatic shafts diameter	25 - 76 mm	1 - 3"
Web guide	BST Ultrasonic	
Inspection System	Nikka, BST Tubescan, AVT	
Printing system (optional)	Domino Gx, HSA Inkjet Thermal, up to 600dpi	
Slitting Station (optional)	Razor knife	
Minimum distance razor	12.7 mm	0.5"
Label Dispenser (optional), max speed	30 m/min	98 ft/min
DIMENSIONS		
W x D x H	2.0 x 1.2 x 1.7 m	6.7 x 3.9 x 5.6 ft.



VARIABLE DATA PRINTING
Personalise your labels with a unique 2D or QR code, text, number, and verify them by a high-resolution camera inspection system.



100% INSPECTION
Bi-directional system allowing the users to back-up and re-check a defective label to make sure the job is 100% perfect.

LR250⁺

Label camera inspection rewinder

- Super low tension rewinding possible
- Prepared for pharma applications
- Two-way rewriter for re-inspection
- Built-in web guide for perfect roll quality
- Full tension control with tension separation nip
- Ready for back numbering and other value-adding features



LR250⁺ inspection rewinder is designed and manufactured to deliver an outstanding performance that will boost your everyday label productivity.

This rewinder is suitable for general label production and more advanced work such as pharmaceutical applications.

The standard configuration of the LR250⁺ includes a count and missing label control for all types of labels. Extra sensors can be added to support clear-on-clear labels, and an integrated web guide ensures perfect roll quality.

The two-way rewriter has web tension control, nip and an adjustable splice table with pneumatic splice clamps. It is equipped with air expansion mandrels with sleeves easily exchangeable to other sizes.

If 100% inspection is required the LR250⁺ is prepared for a camera inspection with PDF verification required for pharma or other critical applications.

Turn the LR250⁺ Rewinder into a mini digital press with the optional full UV inkjet system.

Finally, the LR250⁺ is equipped with an ergonomic lift table to fit operators of all heights.



FULL TENSION CONTROL
Tension separation allows the setting of different values of tension of unwinder and rewriter. This is especially important with thin sensitive materials or materials on a PET liner.

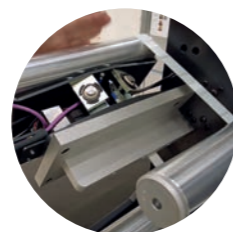

PERFECT ROLL QUALITY
The integrated webguide corrects the position of the web precisely and ensures excellent winding quality even with very narrow rolls.

SPECIFICATIONS	METRIC	IMPERIAL
Max web width	250 mm	9.8"
Max speed	200 m/min	656 ft/min
Max unwind diameter	400 mm	15.7"
Max rewind diameter	400 mm	15.7"
Pneumatic shafts diameter	25.4 - 120 mm	1 - 4.7"
Webguide	BST Ultrasonic	
Inspection system	BST Tubescan, Nikka	
DIMENSIONS		
W x D x H	1.7 x 0.9 x 0.9 m	5.8 x 3.0 x 3.8 ft

LR250

Label inspection rewinder

- Various label inspection functions
- For standard and clear-on-clear labels
- Forward and backwards rewind
- Electronic web tension control
- Simple table rewriter for good quality rolls
- Economical and compact space-saving design



The LR250 is an economical Inspection Rewinder and comes as vertical tabletop model with splicing table and two motor controllers – one working as an unwinder and the other as a rewriter. The design offers control of the web tension which ensures superior winding quality.

The LR250 has expansion mandrels with sleeves easily exchangeable to other sizes. A touch panel makes the operation of the machine very easy with graphic figures showing the rewind direction, and the direction of rotation for the shafts. The machine has an integrated label counter.

The only optional device to be ordered to make the counting and inspection functions active is the relevant sensor. In this way it is easy for the user to upgrade the machine with the different options - the only thing needed is the sensor.

In case of a missing label, the machine stops and places the error on the splice table with high precision.

Other options include splice clamps and extra sleeves with different diameters.



CHOOSE YOUR SENSOR
Depending on your needs, you can select the appropriate sensors for inspection - the missing label system, meter counter, splice detector or the capacitive sensor for "clear-on-clear" labels.



OUTSTANDING REWINDING RESULTS
Get high-quality rolls due to the two motors. One that controls the speed of the unwinder and the other controls the torque of the rewriter.

SPECIFICATIONS	METRIC	IMPERIAL
Web width	250 mm	9.8"
Speed	100 - 300 m/min	328 - 984 ft/min
<i>depending on diameter</i>		
Max unwind diameter	400 mm	15.7"
Max rewind diameter	400 mm	15.7"
Pneumatic shafts diameter	25.4 - 120 mm	1 - 4.7"
DIMENSIONS		
W x D x H	1.3 x 0.8 x 0.8 m	4.3 x 2.6 x 2.6 ft.



Laminators & Coaters

LA330

Laminator

- A lamination and slitting combo machine
- Suitable for digital labels or any other product printed on a roll and presented on a web
- LA330 runs up to 70m/min
- Slit with Automatic Slitting Station



The LA330 is a lamination and slitting combo machine. It runs as an offline unit as standard but can be fitted with a buffer and run inline with a digital press or other equipment.

The LA330 has separate tension control for unwind, lamination and rewind. As standard the process speed is 32m/min, but it can be configured to run up to 70m/min. The LA330 has a soft-touch pressure nip with rubber on both anvil and pressure nip roller. This allows for wrinkle free lamination of everything for standard pressure sensitive labels to OPV solar cells.

The machine can operate both as a slitter-rewinder and as a laminating machine for self-adhesive laminate. It features a special rubber coated laminating nip that ensures curl/wrinkle free lamination.

The machine has an easy to use touch panel and features step-less electronic tension on both unwind and rewind spindles. A web guide with ultrasonic sensor is fitted as standard and has a build-in splice table with two air-controlled clamps.

There are many possible options to the machine: rotary knife box, razor blade system, inkjet head etc.

The rewinder can be set at rewinding label-in or label-out, and many functions are set and defined by touch display.



BEAUTY AND PROTECTION
A roll-to-roll laminator designed to give glossy or matt surfaces onto labels



FLEXIBLE LAMINATION
Unwind with tension control to support laminates with and without backing paper

SPECIFICATIONS	METRIC	IMPERIAL
Web width	330 mm	13" (other sizes on request)
Max speed	70 m/min	300 ft/min
<i>*the higher speed is possible on request</i>		
Webguide	BST Ultrasonic	
Max unwind diameter	600 mm (800 mm optional)	23.6" (31.5" opt.)
Max rewind diameter	500 mm standard	19.7"
Rewind torque	10 - 100 Nm, adjustable on front panel	
Max. roll size	Ø250 mm	9.8"
DIMENSIONS		
W x D x H	2,8 x 1,4 x 1,7 m	9.2 x 4.6 x 5.6"

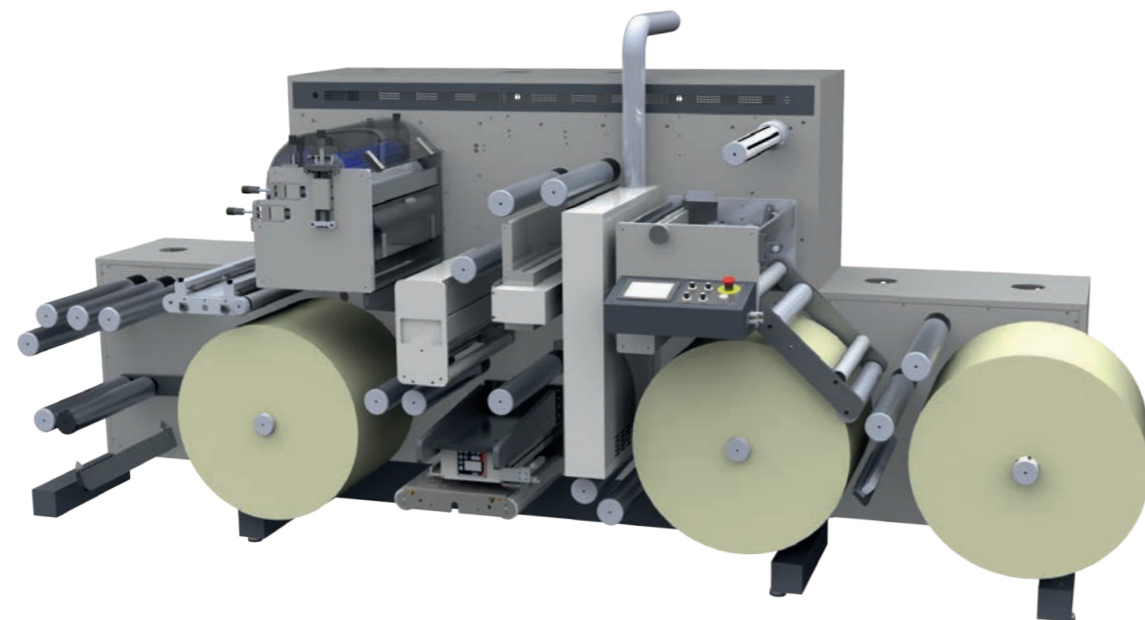

UC500

Coater with lamination & flexo varnish

- Maximum flexibility with UV and water-based varnish
- Hot-air module for water-based varnish
- Ideal for banners, folders and post cards

Coater with lamination and flexo varnish. Single unit in-line or off-line converting for digital workflows. The converting line consists of a UV varnish and lamination/supergloss.

Operation can be both inline with a in-sync unit or offline (optional unwind module). Typical applications are banners, folders, post cards and roll-to-roll printed labels (not die cut).

The line is operated by a touch display and available for web widths of 330mm (13") or 500mm (20").

SPECIFICATIONS	METRIC	IMPERIAL
Web width	100 - 500 mm	4 - 20"
Substrate thickness	20 - 350 µm	0.8 - 13.8 pt
Max. web speed	30 m/min	98.4 ft
Max. web speed with closed chamber	100 m/min	328 ft
UNWIND/REWIND		
Max unwind diameter	700 mm	27.6"
Max rewind diameter	500 mm	19.7"
Max rewind diameter additional roll	700 mm	27.6"
Core diameter	76.2 or 152.4mm	3 or 6"
FLEXO STATION		
Print cylinder size	228 - 482.5 mm	9 - 19"
Spot varnish option with digital sensor register control and slow run		
SLITTING STATION		
Knife type	Pneumatic crush or razor knife	
Minimum distance crush	12.7 mm	0.5"
DIMENSIONS		
W x D x H	2.0 x 1.4 x 1.7 m	6.6 x 4.6 x 5.6 ft

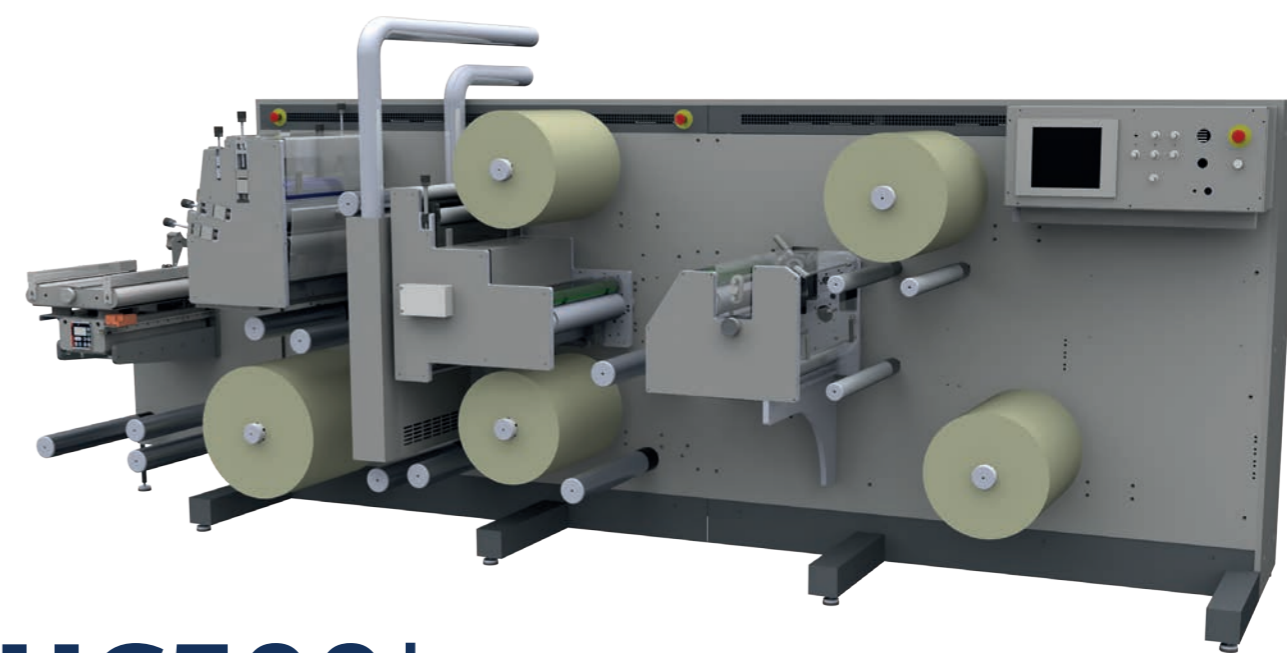

UC500+

Coater with lamination & super gloss

- Touch display setting of label quantity per sheet and other job information
- Automatic register control
- Dual 76mm rewind with Ø500mm capacity
- Optional hot-air for water-based varnish
- Pneumatic 76mm spindles
- Ultrasonic web guide
- UV flexo varnish

The UC500+ coating line is a universal coating/priming unit. It comes as an inline or offline version. Inline versions support all major digital presses.

The machine can be equipped with partial varnish, lamination, super gloss and other coating options. For priming synthetics, a Corona system is needed. Water based coatings will need a closed chamber option in most cases.

The UC500 can be delivered in a "full duplex version" that applies coatings to both sides of the web. The standard 4x1.4 meters UC500 has a more compact sister: the ultra-compact UC500. This light version measures only 2x1.4 meters.

GM delivers the UC500 in both left-right and right-left run direction. Coatings are applied with a flexographic station and can be both UV and water based.

SPECIFICATIONS	METRIC	IMPERIAL
Web width	100 - 502 mm	4 - 20"
Substrate thickness	60 - 200 µm	2.4 - 8 pt
Max. web speed	32 m/min	105 ft
FLEXO STATION		
Print cylinder size	228 - 482.5 mm	9 - 19"
Spot varnish option with digital sensor register control and slow run		
SLITTING STATION		
Knife type	Pneumatic crush or razor knife	
Minimum distance crush	12.7 mm	0.5"
DIMENSIONS		
W x D x H	3.9 x 1.4 x 1.7 m	12.9 x 4.4 x 5.4 ft

DS330

Dual side coater

- Designed for HP Indigo
- High-precision inline coating
- Combine matte, satin and gloss varnishes
- Cast'n'cure holographic effects
- Cold foil effects

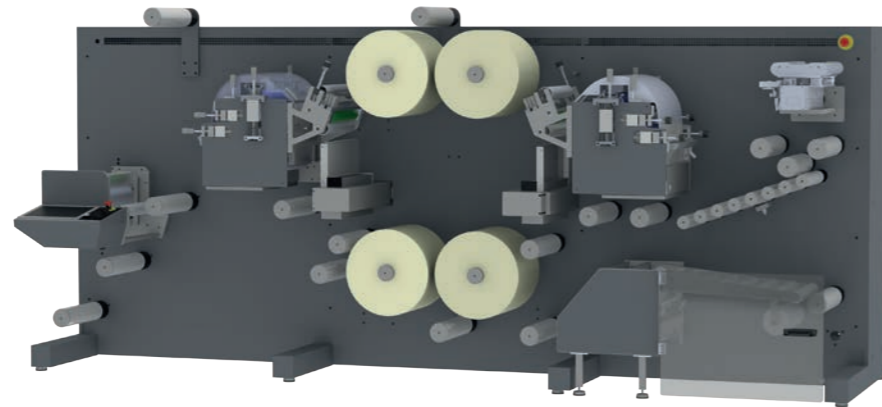

Designed for inline integration with the HP Indigo, the DS330 includes two flexo units capable of applying spot, partial or full surface coating immediately after the printing stage.

The unit is duplex providing protection to both sides of the web. The result is a seamless single-pass roll to roll print and coating operation, resulting in efficiency in logistics, minimum material waste, setup time and handling.

Combination varnish printing with the DC330Flex series opens numerous creative opportunities. Examples of possible effects include a double full-surface coat for extra protection, high-gloss varnish, optional cold foil or combining full, spot or line effects, thus creating contrast or adding vividness to an underlying colour.

The DS330 has a broad substrate range and high speed. It is capable of running 72m/min on substrates between 50 and 180gsm. The inline coater also features corona treatment, quick-change sleeve technology and the ability to switch from UV to water-based varnish within a few minutes.



DUPLEX COATING & LAMINATION
Double-sided coating gives the labels a unique character and surface protection on both sides of the labels.



VARNISH PRINTING
Add an exceptional finish to your print with varnish, glossy or matte surfaces, spot effects or a combinations of these.

SPECIFICATIONS	METRIC	IMPERIAL
Web width	330 mm	13"
Substrate thickness	60 - 200 µm	2.4 - 8 pt
Max. web speed	72 m/min	236 ft
FLEXO STATION		
Printing width max	310 mm	12.2"
Print cylinder size	228 - 482,5 mm	9 - 19"
Spot varnish option with digital sensor register control and slow run		
DIMENSIONS		
W x D x H	3,9 x 1,3 x 1,7 m	12.9 x 4.1 x 5.4 ft

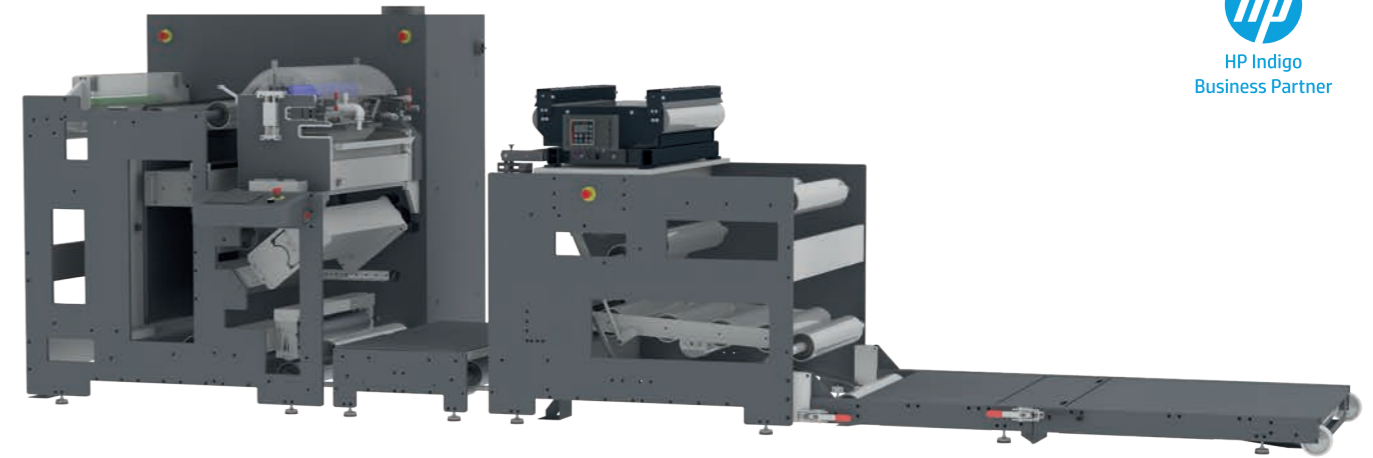

IC30

Inline coater for HP Indigo

- Designed for HP Indigo
- Production of any size job from very small batches to large-scale production
- Fully modular wide web inline-coating system
- Water-based and UV varnish
- Flexible, quick and self-cleaning sleeve-change over

The IC30 is an innovative, inline or offline 30-inch coating system with an optional selective coating solution for flexible packaging films and carton folding substrates.

The IC30 offers state-of-the-art coating and - depends on configuration - is ideal for a wide range of applications, including flexible bags and pouches, shrink sleeves, twists wraps, carton substrates for the pharmaceutical market, cosmetics, consumer electronics, promotional, gifts and more.

IC30 is 100% modular and designed for perfect integration with 30-inch wide digital presses like HP Indigo 20000, 15K, 25K, 35K, 100K.

The IC30 and HP Indigo offer a complete digital printing production line - for printing, full surface or selective coating and stacking. It delivers outstanding ink protection and excellent gloss, matte and soft-touch finishes.

SPECIFICATIONS	METRIC	IMPERIAL
Web width	200 - 762 mm	7.9 - 30"
Substrate thickness	up to 550 µm	21.7 pt.
Max speed	55 m/min	180 ft/min
Webguide	BST Ultrasonic	
FLEXO STATION		
Print cylinder size option 1	228 - 482.5 mm	9 - 19"
Print cylinder size option 2	482.5 - 1016 mm	19 - 40"
Spot varnish option with registration and slow run		
DIMENSIONS		
W x D x H	6.0 x 2.2 x 1.7 m	19.6 x 7.2 x 5.6 ft.



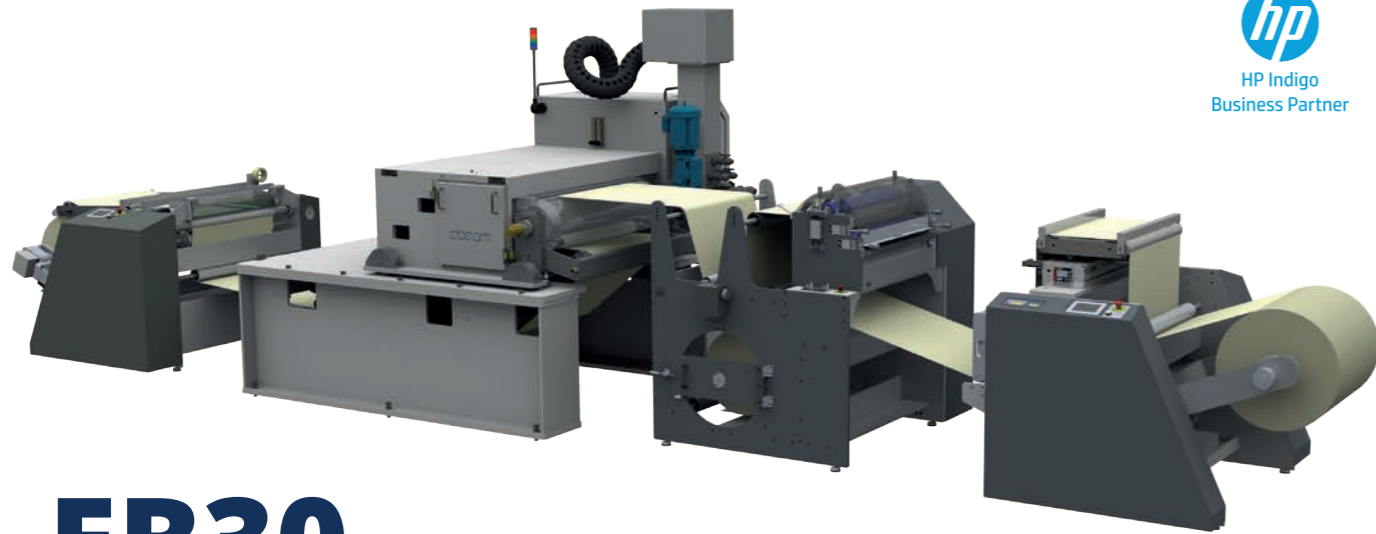

EB30

Ebeam inline coater

- Designed for HP Indigo
- FDA compliant
- Food safe - ideal for flexible packaging
- Fully controlled curing process
- Best TCO on the market

EB30 is an integrated module that features an unwinder (LUW30) varnish/lamination station and a rewinder (LRW30) designed to run in-line with EBEAM systems for curing a substrate. It is also designed as a stand-alone unwinder, varnish station and rewinder system.

EB30 has a user-friendly touch screen interface that allows the operator to operate the machine in an easy way. The machine has an enhanced taper tension control algorithm that ensures that excellent rolls are made.

- Enables Outstanding ink protection and excellent gloss matte and soft-touch finishes
- Increased heat resistance enables heat sealing to form pouches
- No harmful photoinitiators
- Cross-linking thin-film laminating adhesives
- Room temperature process, great for heat-sensitive substrates
- High process efficiency: instant curing, no post-process storage needed

SPECIFICATIONS	METRIC	IMPERIAL
Web width	762 mm	30"
Substrate thickness	50 - 200 µm	2 - 8 pt.
Speed max.	72 m/min	236 ft
Max rewind diameter	500 mm	20"
Max rewind diameter	500 mm	20"
Core diameter	76.2 mm	3"
FLEXO STATION		
Varnishing roller	228 - 406 mm	9 - 19"
Spot varnish option with registration and slow run		
Length approx.	8.6 m	28 ft



XP500

Cardboard finisher

- DUAL UV-flexo varnish
- Optional spot varnish with registration
- Super gloss varnish
- Cold foil silver, gold, and special effects
- Conveyor for sheet processing
- Can work as a rotary sheeter
- Quick job change with magnetic cylinder

The XP500 line is designed to varnish and laminate a 500 mm wide web on both sides and then dice-cut, all in one process. It integrates with your digital press and forms a full production line for postcards, brochures and many other products. The end product is placed on a conveyer or packed in boxes at the end of the line.

Designed for postcards, tags, pocket folders and flyers; the flexible die cutter offers many possibilities. As standard, the line comes with a sling stacking system but more advanced systems can be added and customised with the exact applications you need:

XP500 runs with double tools for bending lines/folders

All-in-all a very service friendly design that requires a minimum of maintenance.

SPECIFICATIONS	METRIC	IMPERIAL
Web width	500 mm	20"
Substrate	80 - 500 µm	3.1 - 19.7 pt
Speed	Up to 72 m/min	Up to 236 ft/min
Die cut repeat range	50 - 558.8 mm	2 - 22"
Max unwind diameter	Ø1200 mm (external unw. option)	
Output to	Conveyor/stacker	
Lamination unwind diameter	Ø400mm	15.7"
Flexo cliché range (dual side)	228 - 482.6 mm	9 - 19"
Knife box	Shear, Crush or Razor	
Core diameter	76.2 mm	3"
UV system	GEW Air cooled	
DIMENSIONS		
W x D x H	7.2 x 1.3 x 1.8 m	23.6 x 4.1 x 5.9 ft



RS350

The next-level rotary sheeter



- Ultra-Fast Performance
- Standard Sheeting Plates
- Versatile Cutting Options
- Servo Driven, Format “Free” Sheeting
- Add-on to your existing GM DC series



Auxiliary equipment

REVOLUTIONIZE YOUR PRODUCTION

Elevate your production process with the RS350, our cutting-edge Rotary Sheeter designed to transform rolls into sheets with unparalleled precision and speed. Engineered to meet the highest standards, this state-of-the-art module ensures efficiency and quality in every operation.

APPLICATIONS

Whether you are producing calendars, photo-books, or intricate die-cut labels, the RS350 Rotary Sheeter is the ultimate solution. Its advanced technology and user-friendly features make it the perfect choice for various sheeting requirements.

INTEGRATION AND OPERATION

The RS350 can be operated as a standalone module with its own unwind system, offering you complete autonomy in your production line. Alternatively, it can be seamlessly integrated with any GM DC series finisher, providing a cohesive and efficient workflow. This flexibility ensures that the RS350 can be tailored to fit the specific needs of your production process.

SPECIFICATIONS	METRIC	IMPERIAL
Web width	50/ 350 mm	2/ 13.8"
Substrate thickness	50/ 350 µm	2/ 13.8 pt
DIE STATION SHEETS WITH SINGLE SIDE CONVEYOR		
Die cylinder	304.8/ 711.2 mm	12/28"
Full-rotary speed	100 m/min	328 ft/min
Variable speed (up to)	50 m/min	164 ft/min
Sheet max size (variable speed)	2000 mm	79"
Sheet min size (variable speed)	150 mm	6"
DIE STATION LABELS (OPTIONAL)		
Die cylinder	304,8/ 711,2 mm	12/ 28"
Full-rotary speed	100 m/ min	328 ft/ min
WEB PATH LENGTH		
Power/ Air	3 X 400V + N + PE, 32A / 6 bar. Tube dimension ø8mm	
Lak current	300mA RCCB type B	

Patch cable internet connection with open ports 80 and 433 for outgoing connections.

Auxiliary equipment



Ultra-Fast Performance
Experience the blazing-fast sheeting capabilities of the RS350. Its high-speed operation significantly enhances productivity, making it ideal for high-demand production environments.



Standard Sheeting Plates
The RS350 is designed to use conventional die-cutting plates, ensuring a seamless integration into your existing setup. This feature eliminates the need for specialized tools, reducing setup time and operational costs.

CS350/550

High Speed Sheeter

- Roll to sheet guillotine cutter
- Cuts labels and heavy materials
- In-line and off-line operation with built-in register control
- User-friendly touch screen for smooth operation
- Cuts according to length, number of labels, or print marks



The CS350 is GM's latest high-speed guillotine sheeter providing cutting with high accuracy of $\pm 0,15$ mm.

The machine cuts web into sheets at a speed of up to 30 m/min or up to 14,000 sheets/hour depending on the selected cutting length.

The CS350 offers a web width of 350mm and operates with most digital label presses on the market. It is built for both in-line and off-line operations, and it is compatible with the entire line of GM converters.

The sheeter is developed to cut not only labels but other heavy materials as carton boxes for the pharmaceuticals and cosmetics sector, folding carton used for packaging in the tobacco industry and display blisters.

The sheeter can be additionally equipped with optional rotating shear knives for length slitting or side cutting, as well as wheels, allowing the machine to be easily moved when needed.

Intuitive setting of operating parameters on the touch display, and the machine cuts according to a very large variety of criterias and contains many time saving options.



HIGH SPEED SHEETER
This high-speed sheeter cuts sheets with a speed of up to 30 m/minute or up to 14,000 sheets/hour.



MULTIPLE USE
Cuts not only labels but other heavy materials as carton boxes for the pharmaceuticals and cosmetics sector, folding carton used for packaging in the tobacco industry and display blisters.

SPECIFICATIONS	METRIC	IMPERIAL
Max. web width	350/550 mm	13.8/21.7"
Min. web width	30 mm	1.18"
Max. sheet length	10 m	33 ft
Min. sheet length	10 mm	0.4"
Cutting accuracy approx.	± 0.15 mm	± 0.006 "
Max. web speed	30 m/min	98 ft/min
Max. speed in sheets	14 000 sheets/hour	
Max. unwind diameter (internal)	800 mm	31.5"
Core diameter	76.2 or 152.4 mm	3 or 6"
Max. roll weight, unwinding	150 kg	331 lb
Power / Air	200 - 240V+N+PE, 13A, 6 bar	
DIMENSIONS		
W x D x H CS350	2.00x120x1,75 m	6.6x3.9x5.7 ft

CC160/200

Core Cutters

- High precision feeding and cutting
- Job change within a few minutes
- Production and job setting information
- Automatic adjustment of machine operation for selected core size and wall thickness.
- Option for 1/2-inch cores



The CC160/200 Semi-automatic Core Cutters provide high precision feeding and cutting of cardboard cores of optional length and sizes at high speeds.

CC160/200 are operated by a user-friendly touch display with graphic symbols. It automatically adjusts all machine operations to the selected core size and wall thickness.

The changeover from job to job is easily done within a few minutes. The core cutter is operated by a user-friendly touch display with graphic symbols and automatically adjust all machine operations to the selected core size and wall thickness.

SPECIFICATIONS	METRIC	IMPERIAL
Cutting speed	Max. 40 - 70 cuts/min <i>Depending on core size and material</i>	
Core diameters <i>One adapter set needed for each diameter</i>	12.7 - 152.4 mm	0.5 - 6"
Max core length	1600 or 2000 mm	63" or 78.7"
Material thickness	Max. 15 mm	0.59"
Air supply	Min. 4 bar	
Electricity supply	200 - 240V+N+PE, 13A	
DIMENSIONS		
W x D x H CC160S	3.0x0.5x1.5 m	9.8x1.6x4.9 ft
W x D x H CC200S	3.4x0.5x1.5 m	11.1x1.6x4.9 ft



STEEL ANVIL FOR PRECISION
CC160/200 is born with a steel anvil for high precision cutting of cores. Other anvils are available for different core sizes and wall thicknesses.

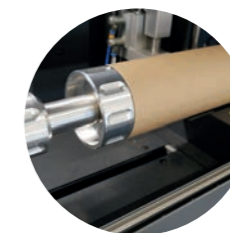

CORES UP TO 6"
CC160/200 can cut cores down to 6" in diameter with high precision cutting.



QuickMount

Fast set-up and job changeover

- For very fast mount of male/female embossing plates
- Job change within a few minutes
- No need to cut the foil and substrate
- Set-up and job changeover has never been faster and easier!



ELIMINATE STOPS
Prepare your top-plates outside the machine and eliminate the need to stop the machine to cut the foil web during a job change.

When embossing, QuickMount makes set-up and job changeover faster, simpler, and more efficient. QuickMount enables very fast mount of the die and/or counter force plate.

This new mounting tool that can save the operator many hours in job change time every week, as job changeover can be accomplished, on average, in as little as a few minutes.



FAST JOBCHANGE
Very fast mounting of the die and/or counter force plate when embossing.

Now the operator can prepare your top-plates outside the machine and eliminate the need to stop the machine to cut the foil web during a job change.

For even faster job change we recommend working with an extra top-plate to save even more operator time.

Set-up and job changeover has never been faster and easier!

SPECIFICATIONS	METRIC	IMPERIAL
Use of tool	For GM original tool plates.	
Plate thickness combined (Die and counter)	16 -15 mm	0.5 - 6"
Max. web width	350/550 mm	13.8/21.7"

RL Roll Lifter

Mobile lifting units for the handling of paper rolls. The RL-line includes three models with different lifting heights and manual or automatic lifting. The RL roll lifter unit consists of a solidly welded frame, two fixed front wheels and two revolvable rear wheels. The legs of the lifter fit under a standard EU pallet.

Both hydraulic and electric models are available: The RL 14 is designed with a foot-operated hydraulic pump and gear train for easy lifting and lowering. In the RL14EL this is done by an electric actuator and controlled by a wired controller.

The support shaft is fitted with ball bearings on the top side and can easily be replaced by a yoke which is applied when the roll including the shaft is to be lifted from a machine.

OPTIONAL:

- Lifting yoke for handling of rolls of max. width 700 mm (27.6")
- Support shaft of 610 mm (24") for rolls of max. width of 610 mm
- Extra battery (only RL14EL)

SPECIFICATIONS	METRIC	IMPERIAL
Lifting height	100 - 1500 mm	3.9 - 59"
Max. roll weight	350 kg	770 lbs
Lifting system	Manual hydraulic foot pump	
Weight	110 kg	242 lbs



Auxiliary equipment

GM Camera inspection systems

GM offers systems that are bi-directional, which allows the users to back up and re-check a defective label making sure the job is 100% perfect. The inspection camera system stops the machine when a fault has been detected and moves the faulty label back to the repair table. The system can be fitted with cameras from BST, Nikka, AVT, or other suppliers according to client requirements.

In addition to the basic functions of detecting print defects, missing labels, or counting labels, the inspection systems can also be equipped with extremely useful functions such as:

- Verification of barcodes, QR codes, data matrix, etc.
- UV illumination for security print with UV luminescent ink or partial UV varnish
- Additional lighting for inspection of transparent labels and for Braille
- Backlight illumination using the light line with high intensity for pinhole detection or buried antennae structures in RFIDs
- Variable Data Processing (VDP)
- High-definition cameras - 4K/8K





GR80K

Shredder with built-in waste removal unit. Designed to shred a wide range of material and reduce it to approx. 5 - 10 % of the original volume.

SPECIFICATIONS	METRIC	IMPERIAL
Max. trim width	30 mm	1.2"
Max. trim extraction speed	250 m/min	820 ft/min
Connection tube diameter inlet int/ext dimensions	2x56 / 2x63 mm	2 x 2.2" / 2 x 2.5"
Dimensions (LxWxH)	0.7 x 0.7 x 0.9 m	2.3 x 2.3 x 3 ft

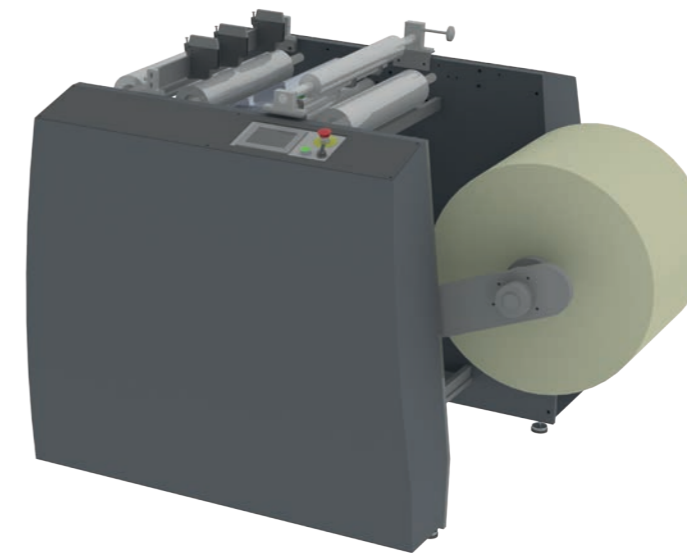

LRW500 - Rewind Unit

For the heaviest and most demanding jobs, GM offers this multi-purpose, stand-alone rewinding unit with splice table, web guide and slitting knife. The entire module is electronically synchronized and capable of communicating with a variety of printing systems.

SPECIFICATIONS	METRIC	IMPERIAL
Web width	500 mm	19.7"
Max. roll diameter	1200 mm	47.2"
Max. roll weight	750 kg	1653 lbs
Max. speed*	30 m/min	98 ft/min
	<i>*higher on request</i>	
Substrate support	40 - 350 gsm paper and film	

GR100

The GR100 Waste Shredder is designed for inline use with GM fast slitter rewinders and finishing units as well as printing machines for removing and shredding the side trim. The shredder efficiently cuts a variety of materials including paper, foil, film, plastics, and cardboard, and reduces them to just a few per cent of their original volume.

The bag can be changed very easily and quickly. This continuous liner system makes it possible to replace bags in a completely sealed and dust-free manner.



SPECIFICATIONS	METRIC	IMPERIAL
Max. trim width*	30 mm	1.2"
Max. speed*	300 m/min	984 ft/min
Connection tube diameter	1x80 / 2x50 mm	1 x 3.1" / 2 x 2"
Dimensions (LxWxH)	1.1 x 0.6 x 1.7 m	3.7 x 2.0 x 5.7 ft

**Max. trim width and max speed depend on the substrate*

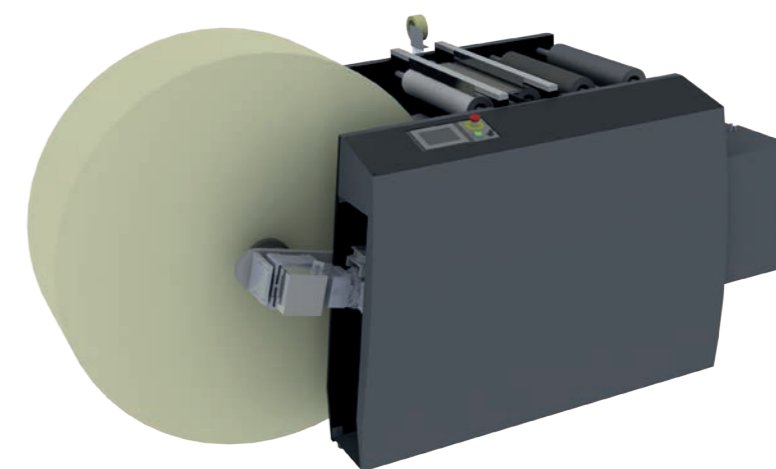

SPECIFICATIONS	METRIC	IMPERIAL
Web width	500 mm	19.7"
Max. roll diameter	1500 mm	59"
Max. roll weight	750 kg	1653 lbs
Max. speed*	30 m/min	98 ft/min
	<i>*higher on request</i>	
Substrate support	40 - 350 gsm paper and film	

LUW500 - Unwind Unit

For the heaviest and most demanding jobs, GM offers this multi-purpose, stand-alone unwinding unit with splice table, web guide and slitting knife. The entire module is electronically synchronized and capable of communicating with a variety of printing systems. Unit has a low unwind signal for press.

Configuration examples

SR350 Slitter inspection rewinder combined with **DC350 Nano** finishing line. This configuration enables inspection, die cutting, laminating, slitting and rewinding in a single pass.

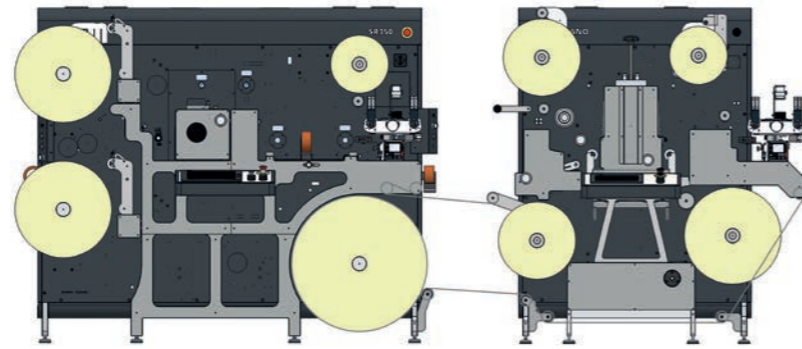

LC350 custom laser finishing line for special applications. The configuration includes two laser modules and two label applicators.

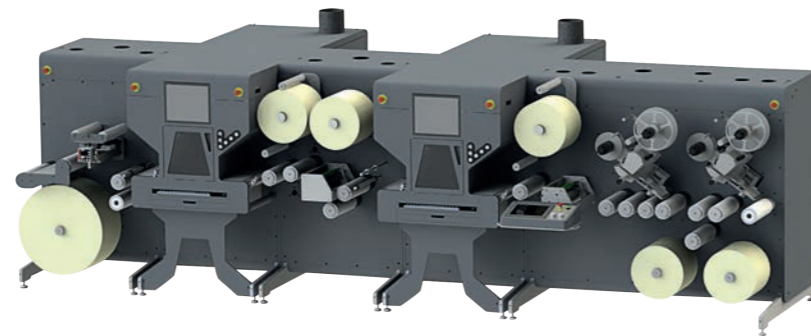

DC350Flex+ Wine is a premium Wine Label Finisher. High quality 50-ton flatbed foil stamping and digital varnish with the DVM350, along with servo register and foil saver. Embossing and hot foiling can be done using the same tool.



DC350Flex+ finishing line with combined 50-ton high quality flatbed hot foil stamping and flatbed screen printing. In addition semi-rotary flexo station, semi-rotary die cutting, FastStrip, AutoKnives, and dual rewinder.



DC350Flex finishing line with digital varnish (DVM350) and Multilayer option. In addition, semi-rotary flexo station, semi-rotary die cutting, FastStrip, AutoKnives, and dual rewinder.

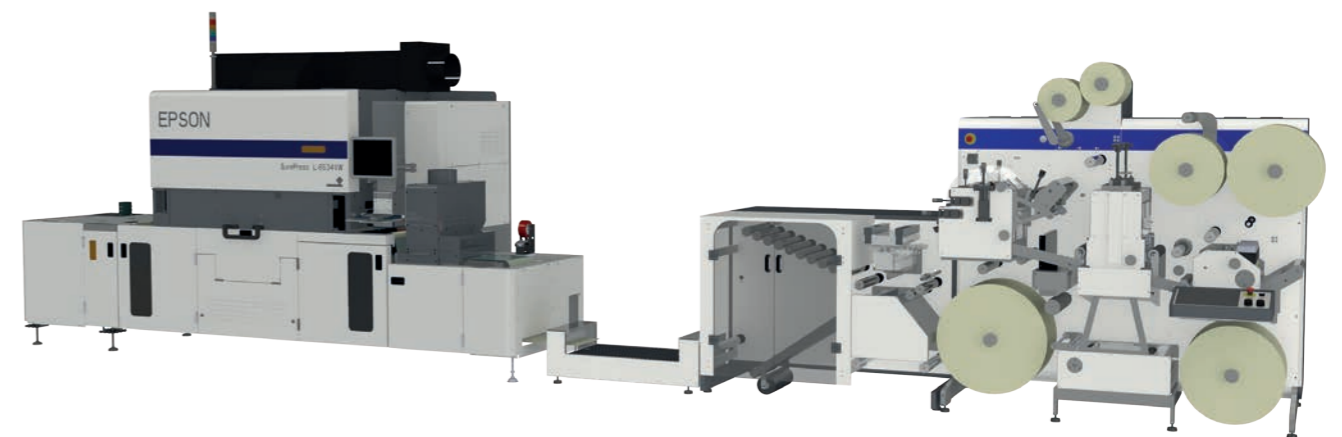

DC330MINI finishing line with inline option for Epson SurePress and other digital presses. This configuration offers compact and economic processing of labels. **Features:** synchronizer, flexo varnish, spot varnish, lamination and cold foil, semi-rotary die cutting, slitting and rewinding on dual rewinder.



GRAFISK MASKINFABRIK A/S
Klintehøj Vænge 12, 3460 Birkerød
Phone: +45 4581 2300
Email: gm@gm.dk
Web: www.gmfinishing.com

Specifications and terms are subject to change without notice. All product and brand names are trademarks and/or registered trademarks of their respective companies. GM disclaims any and all rights in these marks.

For more information, please visit www.gmfinishing.com

